



MILWAUKEE SLIDE AND SPINDLE

Precision Slides for the Industry

SLIDE HANDBOOK



FAMCO
MACHINE DIVISION



GORTON



MILWAUKEE
SLIDE AND
SPINDLE



MILWAUKEE SLIDE AND SPINDLE

A SUBSIDIARY OF FAMCO MACHINE

HOW TO ORDER

KEY TO SLIDE DIMENSION CHARTS

- | | |
|--|----------------------------|
| H = Height | CH = Carrier Height |
| W = Width | T = Travel |
| D = Depth | K = Key Dimension |
| BH = Base Height | LA = Linkage Addition |
| Y = Length Centers Spacing
Between Mtg Screws | C = Recess |
| R = Hole Center Line to End | L = Lead Screw Center Line |
| HD = Hole Diameter | A = Way Width |
| WC = Width Center | B = Dove Tail Minimum |
| BL = Base Length | S = Gib Screw Spacing |
| CL = Carrier Length | F = Dove Tail Maximum |

SLIDE MODEL CODE DESCRIPTION

RB12-30-20-BSP-MMT-22-3LS-M-9T

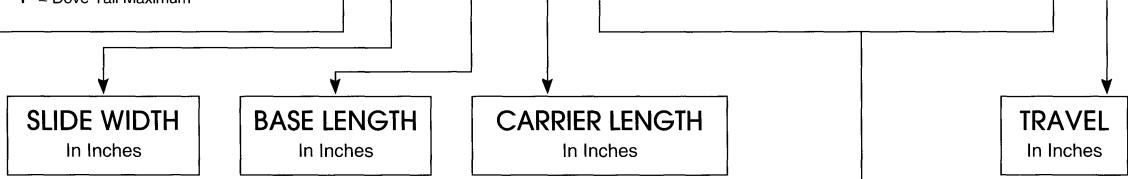

SLIDE TYPE

Dovetail
 R=Regular duty
 H=Heavy duty
 RB=Recessed base
 RBF=Recessed & flanged base
 IPM=Recessed base

Ball Way
 HB=High profile
 HUB=Low profile
 HBL=Low profile single way

Hardened Way
 HW=High profile
 HWL=Low profile

ACCESSORIES

ABN=Anti-backlash nut for lead screw ACC=Air cylinder drive ACC=Air cylinder drive with Hydro-Check® ALS=Automatic lube system AWC=Thermic-Weld™ accordion way covers AWC(A)=Thermic-Weld™ accordion way covers with Armor-Plate™ laminations Bn=Additional bearing slide units (4 bearing slide units are standard on HB and HUB slides) BSP=Precision ground ball screw, single preloaded nut BSP(D)=BSP with double nut, spacer BSR=Rolled ball screw, single nut BSR(D)=BSR with double nut, spring washers CC=Counterbalanced crank handle and graduated dial knob CMH=Customer mounting hole CW=Cavity wiper EP=End plate G=Surface ground ways GL=Gib lock GS=Graduated scale HC=Hydraulic cylinder drive	HF=Hand flaked ways HW=Hand wheel IAC=Internal air cylinder drive IHC=Internal hydraulic cylinder drive IPS=Internal positive stop KEY=Keyslot in slide KG=Keeper gibbs, both keepers KK=Knurled knob only L(A)=Acme thread lead screw drive with thrust bearings L(V)=Vee thread lead screw drive with thrust bearings L(LHRH,A)=Left hand-right hand lead screw assembly, acme thread L(LHRH,V)=Left hand-right hand lead screw assembly, vee thread LSL=Lead screw lock LUBE=Lubrication provisions 1LS=1 limit switch & trip system 2LS=2 limit switches & trip system 3LS=3 limit switches & trip system M=Milled ways MCC=Metal cavity cover on HW slides MMO=Motor mount, offset	MMT=Motor mount, inline MPS=Micrometer positive stop MRO=Mechanical readout MWC=Telescopic metal way covers NP=Electroless nickel plating OSL=One-shot lube system PG=Pinned gib PGL=Pneumatic gib lock PI=Position indicator PS=Positive stop RA=Right angle drive RHG=Right hand gib RS=Round shaft RSR=Riser mounted to slide RUC=Roll up cover, both ends S=Hand scraped ways SA=Shock absorber SH=Special height SR=Stop rod SS=Stainless steel construction STL=Steel construction TEE=Tee slot in slide TG=Tapered gib TURC=Turcite® covered ways WL=Way lock WW=Way wipers
--	--	---

STANDARD TYPE SLIDES

All Regular Duty and all Heavy Duty Style slides are constructed of Normalized High Tensile Close-grain cast iron and have accurately milled or ground way surfaces which provide easy and efficient operation under normal work loads.

SPECIAL METALS

When special metals are desired in making your slides these can be provided to fit your individual needs. Quotations for these special slides, made according to your specifications, will be furnished upon request.

TABLE OF CONTENTS

Regular Duty Basic Style	4 & 5	Ball Way Slide Assemblies	18
Regular Duty Lead Screw	6	Low Profile Ball Slides	19
Regular Duty Air or Hydraulic Cylinder	7	Ball Slide Design Principles	20
Heavy Duty Basic Style	10 & 11	High Profile Ball Slides	21
Heavy Duty Lead Screw	13	Special Profile Ball Slides	22
Heavy Duty Recessed Base	12	Angle Plates and Swivels	23
Heavy Duty Recessed Base Lead Screw	14	Accessories	24 & 25
Heavy Duty Air or Hydraulic Cylinder	8	Applications	34-38
Air Cylinder Powered	9	Application Engineering Data	26-29
IPM Dovetail Slides	15	Tolerances/Linear Bearings/Lubrication	31
Hardened Steel Way Slides	16 & 17	Machine Bases	32 & 33
		Useful Technical Data	39
		Lubrication Specification	30

Catalog SL 0200 supersedes all previous catalogs. We reserve the right to change specifications in this MILWAUKEE SLIDE AND SPINDLE catalog without prior notice and without obligation. COPYRIGHT © 1998 by BELCO INDUSTRIES, INC.

FOR AUTOMATED FEEDING APPLICATIONS

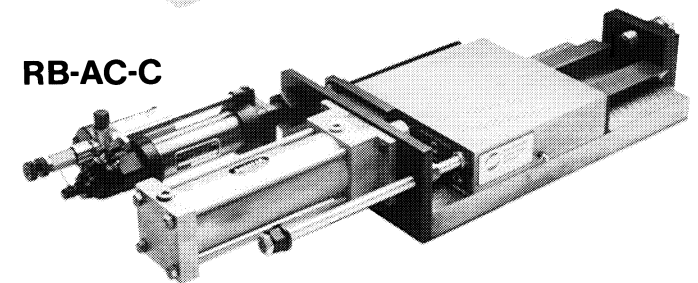
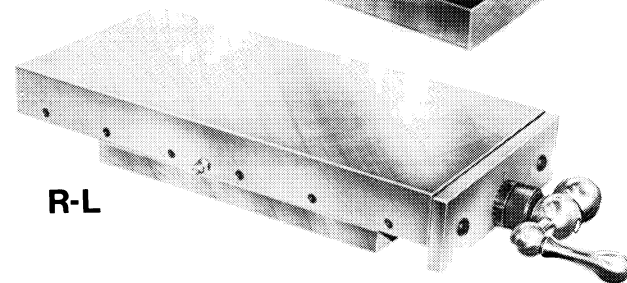
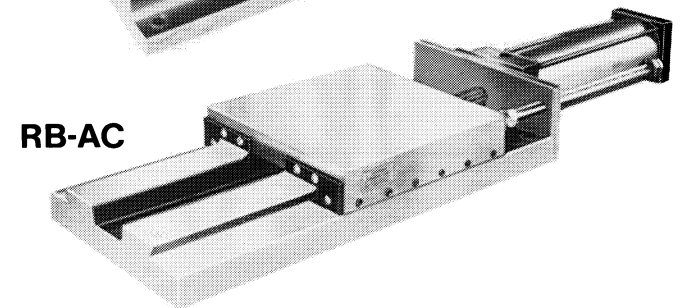
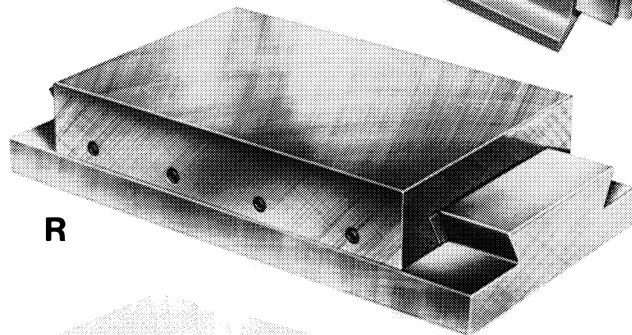
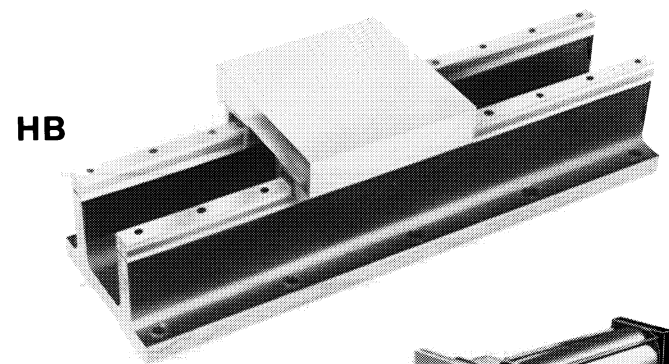
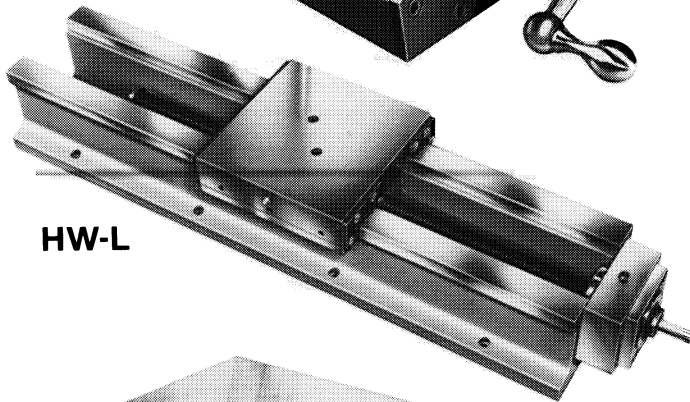
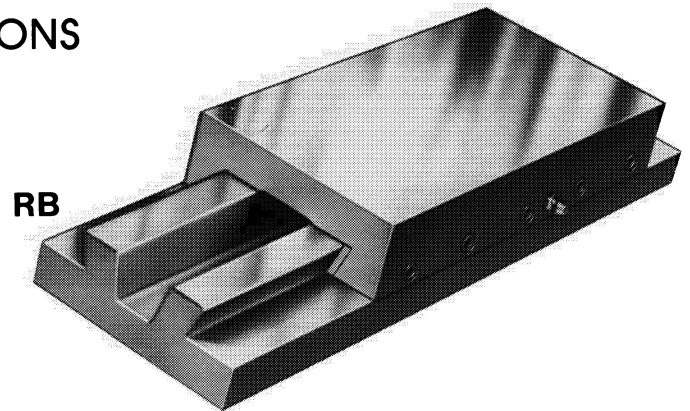
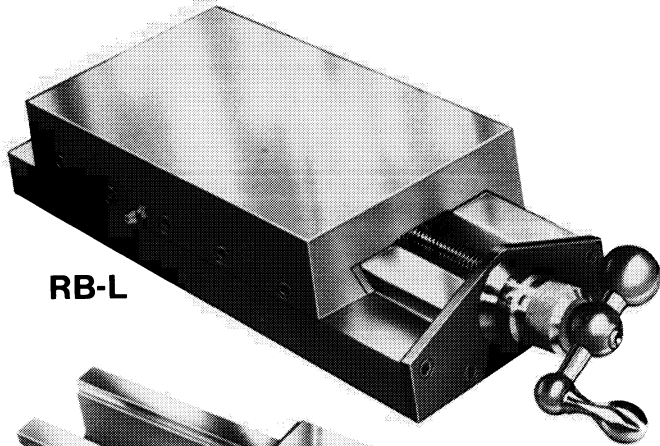

MILWAUKEE PRECISION SLIDES . . .

are ready-made tracks that move on low friction or bearing ways to serve as motion guides for feeding and retracting parts . . . tool . . . or fixtures . . . on all types of machinery. Each basic slide consists of a carrier and a base, both made of specially controlled cast iron, with precision milled/ground dovetail or hardened steel ways fitted together with a steel gib and gib screws for adjustment to insure accurate movement. Milwaukee Precision Slides provide precise line movement regardless of whether it be vertical or horizontal.

VARIATIONS TO SUIT YOUR NEEDS

In the event that none of the standard slide assemblies illustrated in this catalog will fill your specific needs, we suggest you tell us your particular problem.

No matter how complex your needs for slide assemblies may be, our engineering department has experience with all types of slide applications in the modern machine tool industry. Their recommendations for the most economical assembly construction you can use are always available to you without obligation.



SLIDE PROFILES

Full Scale

REGULAR DUTY BASIC MACHINE SLIDES

Standard Regular Duty MILWAUKEE SLIDE AND SPINDLE slides are useful for a broad range of applications where the load induced into the assembly is moderate and a compact design is essential. These basic type slides, with easily adjusted gibs, insure accurate motion and offer a wide range of uses in the construction of automated machines.

Regular Duty Basic slides can be supplied with reduced overall height to meet your applications or replacement needs.

These slide assemblies consist of a carrier, base, gib and gib adjusting screws. They are available for design applications where the means for mounting, movement, and other requirements are provided by the customer.

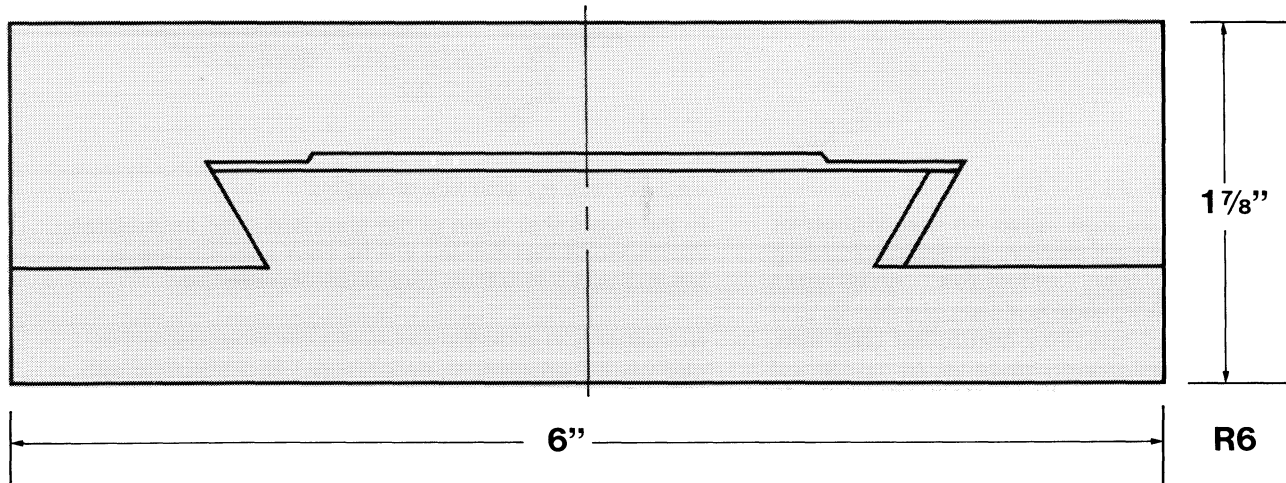
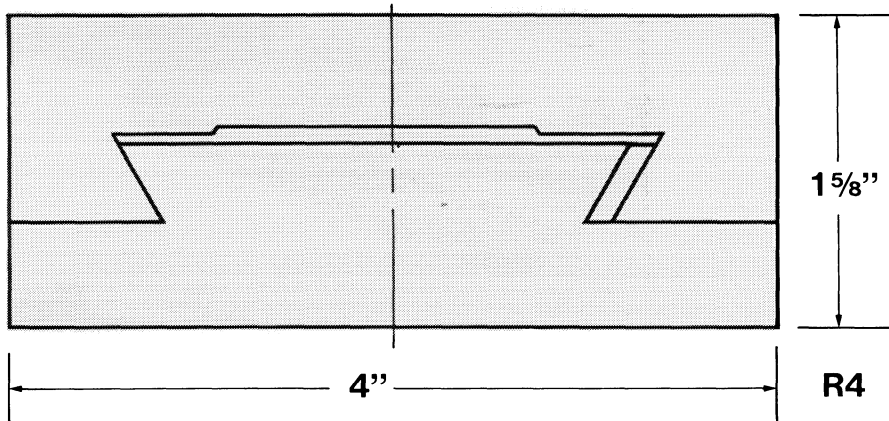
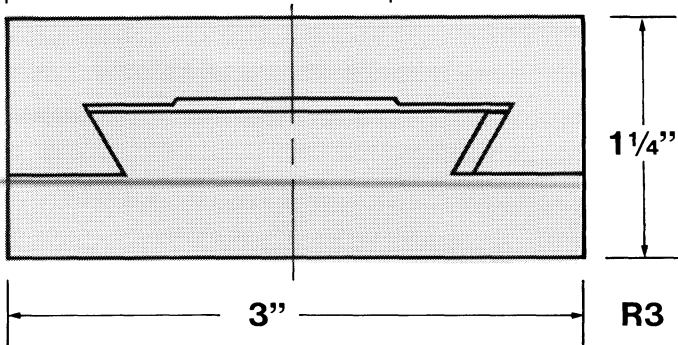
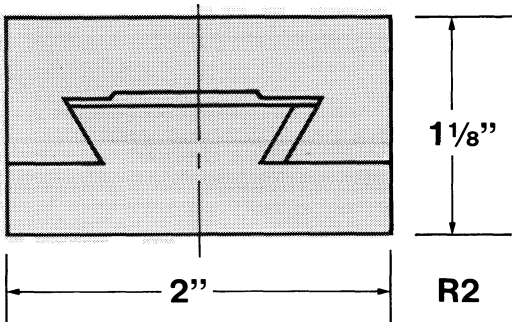

REGULAR DUTY BASIC STYLE



FIG. 1

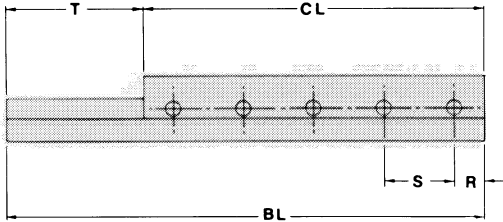
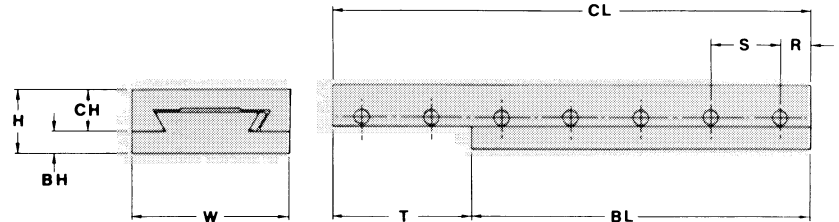

FIG. 2



26 STANDARD MODELS
Gib lock handle available at additional cost

WAY WIPERS ARE OPTIONAL

Model Number	Fig.	Slide Width W	DIMENSIONS IN INCHES						Gib Screws	Gib Screw Spacing		Weight (lbs.)
			T	H	BH	CH	CL	BL		S	R	
R-22¼3	2	2"	¾	1⅛	⅜	¾	3	2¼	3	1	½	1½
R-232¼	1		¾	1⅛	⅜	¾	2¼	3	2	1½	⅜	1½
R-234	2		1	1⅛	⅜	¾	4	3	3	1⅜	⅝	2
R-243	1		1	1⅛	⅜	¾	3	4	3	1	½	2
R-246	2		2	1⅛	⅜	¾	6	4	4	1½	¾	3
R-264	1		2	1⅛	⅜	¾	4	6	3	1⅜	⅝	3
R-334	2	3"	1	1¼	⅞	13/16	4	3	3	1⅜	⅝	3½
R-343	1		1	1¼	⅞	13/16	3	4	3	1	½	3½
R-345	2		1	1¼	⅞	13/16	5	4	4	1¼	⅝	4½
R-354	1		1	1¼	⅞	13/16	4	5	3	1⅜	⅝	4½
R-346	2		2	1¼	⅞	13/16	6	4	4	1½	¾	5
R-364	1		2	1¼	⅞	13/16	4	6	3	1⅜	⅝	5½
R-456	2	4"	1	1⅝	9/16	1⅛	6	5	4	1½	¾	9¼
R-465	1		1	1⅝	9/16	1⅛	5	6	4	1¼	⅝	9½
R-468	2		2	1⅝	9/16	1⅛	8	6	4	2	1	12¼
R-486	1		2	1⅝	9/16	1⅛	6	8	4	1½	¾	12
R-4810	2		2	1⅝	9/16	1⅛	10	8	5	2	1	15¼
R-4108	1		2	1⅝	9/16	1⅛	8	10	4	2	1	15¼
R-4912	2		3	1⅝	9/16	1⅛	12	9	6	2	1	18
R-4129	1		3	1⅝	9/16	1⅛	9	12	6	1⅝	7/16	17¼
R-668	2	6"	2	1⅞	⅝	1¼	8	6	4	2	1	20¼
R-686	1		2	1⅞	⅝	1¼	6	8	4	1½	¾	20½
R-6812	2		4	1⅞	⅝	1¼	12	8	6	2	1	29
R-6128	1		4	1⅞	⅝	1¼	8	12	4	2	1	29
R-61216	2		4	1⅞	⅝	1¼	16	12	8	2	1	40½
R-61612	1		4	1⅞	⅝	1¼	12	16	6	2	1	41

* LUBRICATION — Provision is made for lubrication on all slide models in sizes 6 inch, Regular and up, including all sizes of Heavy Duty Slides.

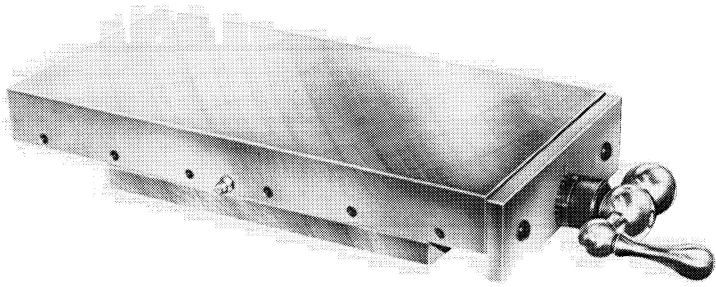

REGULAR DUTY LEAD SCREW MACHINE SLIDES

These Regular Duty Lead Screw equipped slide assemblies are most useful where accurate manual positioning or feeding is required. Standard features are a precision lead screw, graduated micrometer dial to indicate carrier movement and a balanced crank handle for ease in advancing and retracting the carrier or base. Knurled knobs are ideal for finer adjustment where space is limited.

Base mounting holes and carrier mounting holes are quoted at optional cost. Customer to supply dimensional data.

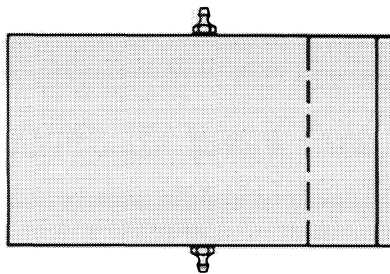

Style "B"
(Knurled Knob)

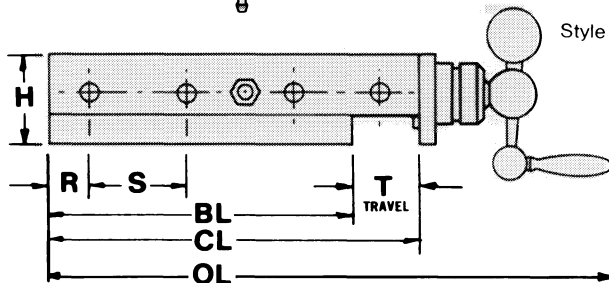

Style "A" (Balanced Crank Handle)

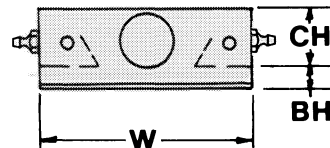

13 STANDARD MODELS OR FURNISHED AS REQUESTED
Gib lock handle available at additional cost

WAY WIPERS ARE OPTIONAL

Model Number	Slide Width W	DIMENSIONS IN INCHES							Gib Screws	Gib Screw Spacing		Thread TH	Est. Weight (lbs.)
		T	H	BH	CH	CL	BL	OL		S	R		
R-22 ¹ / ₄ 3L	2"	3/4	1 1/8	3/8	3/4	3	2 1/4	5 11/16	3	1	1/2	5/16-40 Vee Type	2
R-234L		1	1 1/8	3/8	3/4	4	3	6 11/16	3	1 3/8	5/8		2 1/2
R-246L		2	1 1/8	3/8	3/4	6	4	8 11/16	4	1 1/2	3/4		3 1/4
R-334L	3"	1	1 1/4	7/16	13/16	4	3	6 11/16	3	1 3/8	5/8	5/16-40 Vee Type	4
R-345L		1	1 1/4	7/16	13/16	5	4	7 11/16	4	1 1/4	5/8		5
R-346L		2	1 1/4	7/16	13/16	6	4	8 11/16	4	1 1/2	3/4		5 1/4
R-456L	4"	1	1 5/8	9/16	1 1/16	6	5	9 5/8	4	1 1/2	3/4	1/2-20 Vee Type or 1/2-10 Acme	10 1/4
R-468L		2	1 5/8	9/16	1 1/16	8	6	11 5/8	4	2	1		13
R-4810L		2	1 5/8	9/16	1 1/16	10	8	13 5/8	5	2	1		16
R-4912L		3	1 5/8	9/16	1 1/16	12	9	15 5/8	6	2	1		19
R-668L	6"	2	1 7/8	5/8	1 1/4	8	6	12	4	2	1	5/8-20 Vee Type or 5/8-10 Acme	22
R-6812L		4	1 7/8	5/8	1 1/4	12	8	16	6	2	1		31
R-61216L		4	1 7/8	5/8	1 1/4	16	12	20	8	2	1		42

* LUBRICATION — Provision is made for lubrication on all slide models in sizes 6 inch, Regular and up, including all sizes of Heavy Duty Slides. Acme thread available at reasonable extra cost.

AIR OR HYDRAULIC CYLINDER

REGULAR DUTY



AIR OR HYDRAULIC CYLINDER POWERED REGULAR DUTY BASIC SLIDES

These Regular Duty Cylinder powered slide assemblies are recommended both for quick-action movements and for repeatability, in tooling, fixturing, and parts positioning.

Working pressures of 500 P.S.I. for hydraulic and 250 P.S.I. for air operated cylinders. Double acting non-cushioned cylinders are standard. Special cushioning and/or valving can be provided upon request for a slight extra cost.

Base mounting holes and carrier mounting holes are quoted at optional cost. Customer to supply dimensional data.

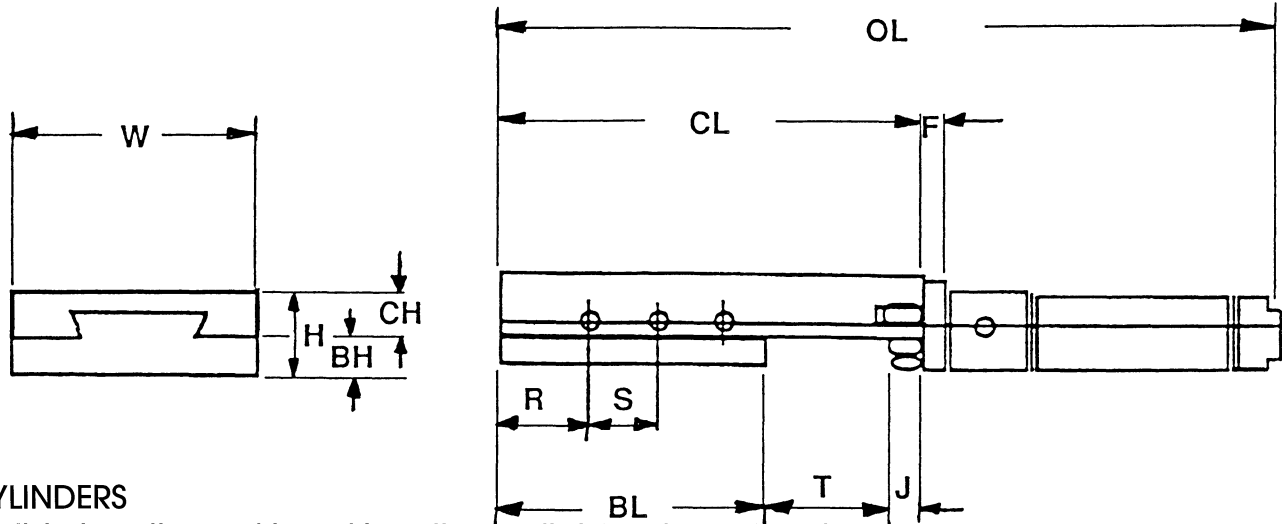

AIR CYLINDERS

Other slide lengths and travel lengths available, please inquire

Model Number	Width W	DIMENSIONS IN INCHES								Gib Screw	Spacing			
		H	BH	CH	T	BL	CL	OL	Bore		S	R	F	J
R2-4-6-AC	2"	1 $\frac{1}{8}$ "	$\frac{3}{8}$ "	$\frac{1}{4}$ "	1 $\frac{1}{2}$ "	4	6	8.1	$\frac{1}{2}$ "	4	1 $\frac{1}{2}$ "	$\frac{3}{4}$ "	$\frac{1}{4}$ "	0.56
R3-3-4-AC	3"	1 $\frac{1}{4}$ "	$\frac{7}{16}$ "	$\frac{3}{16}$ "	$\frac{1}{2}$ "	3	4	7.4	1 $\frac{1}{16}$ "	3	1 $\frac{1}{8}$ "	$\frac{5}{8}$ "	$\frac{1}{4}$ "	0.56
R3-4-5-AC	3"	1 $\frac{1}{4}$ "	$\frac{7}{16}$ "	$\frac{3}{16}$ "	$\frac{1}{2}$ "	4	5	8.4	1 $\frac{1}{16}$ "	4	1 $\frac{1}{4}$ "	$\frac{5}{8}$ "	$\frac{1}{4}$ "	0.56
R3-4-6-AC	3"	1 $\frac{1}{4}$ "	$\frac{7}{16}$ "	$\frac{3}{16}$ "	1 $\frac{1}{2}$ "	4	6	10.4	1 $\frac{1}{16}$ "	4	1 $\frac{1}{2}$ "	$\frac{3}{4}$ "	$\frac{1}{4}$ "	0.56
R4-6-8-AC	4"	1 $\frac{1}{2}$ "	$\frac{1}{2}$ "	1 $\frac{1}{16}$ "	1 $\frac{1}{2}$ "	6	8	13.4	1 $\frac{1}{4}$ "	4	2	1	$\frac{1}{2}$ "	0.62
R4-8-10-AC	4"	1 $\frac{1}{2}$ "	$\frac{1}{2}$ "	1 $\frac{1}{16}$ "	1 $\frac{1}{2}$ "	8	10	15.4	1 $\frac{1}{4}$ "	5	2	1	$\frac{1}{2}$ "	0.62
R4-9-12-AC	4"	1 $\frac{1}{2}$ "	$\frac{1}{2}$ "	1 $\frac{1}{16}$ "	2 $\frac{1}{2}$ "	9	12	18.4	1 $\frac{1}{4}$ "	6	2	1	$\frac{1}{2}$ "	0.62
R6-6-8-AC	6"	1 $\frac{1}{2}$ "	$\frac{3}{8}$ "	1 $\frac{1}{4}$ "	1 $\frac{1}{2}$ "	6	8	13.1	1 $\frac{1}{2}$ "	4	2	1	$\frac{1}{2}$ "	0.62
R6-8-12-AC	6"	1 $\frac{1}{2}$ "	$\frac{3}{8}$ "	1 $\frac{1}{4}$ "	3 $\frac{1}{2}$ "	8	12	19.1	1 $\frac{1}{2}$ "	6	2	1	$\frac{1}{2}$ "	0.62
R6-12-16-AC	6"	1 $\frac{1}{2}$ "	$\frac{3}{8}$ "	1 $\frac{1}{4}$ "	3 $\frac{1}{2}$ "	12	16	23.1	1 $\frac{1}{2}$ "	8	2	1	$\frac{1}{2}$ "	0.62

HYDRAULIC CYLINDERS

Model Number	DIMENSIONS IN INCHES							
	BL	CL	T	F	J	OL	Bore	W
R2-3-4.4-HC-1T	3	4.4	1	0.75	0.44	9.2	1 $\frac{1}{16}$ "	2
R3-3-4.4-HC-1T	3	4.4	1	0.75	0.44	9.2	1 $\frac{1}{16}$ "	3
R4-5-6.6-HC-1T	5	6.6	1	0.82	0.59	11.5	1 $\frac{1}{2}$ "	4
R6-6-8.6-HC-1T	6	8.6	2	0.82	0.59	14.5	1 $\frac{1}{2}$ "	6



**MILWAUKEE
SLIDE AND
SPINDLE**

AIR OR HYDRAULIC CYLINDER

HEAVY DUTY

AIR OR HYDRAULIC CYLINDER POWERED HEAVY DUTY RECESSED BASE MACHINE SLIDES

These Heavy Duty Cylinder Powered slide assemblies are recommended both for quick-action movements and for repeatability in moving equipment at controlled speeds and distances.

Working hydraulic pressure is 800 p.s.i. maximum. Air pressure is 250 p.s.i. maximum. Special cushioning and/or valving can be provided upon request or a slight extra cost.

These slide assemblies are hand flaked and furnished with a stop rod and alignment coupler as standard.

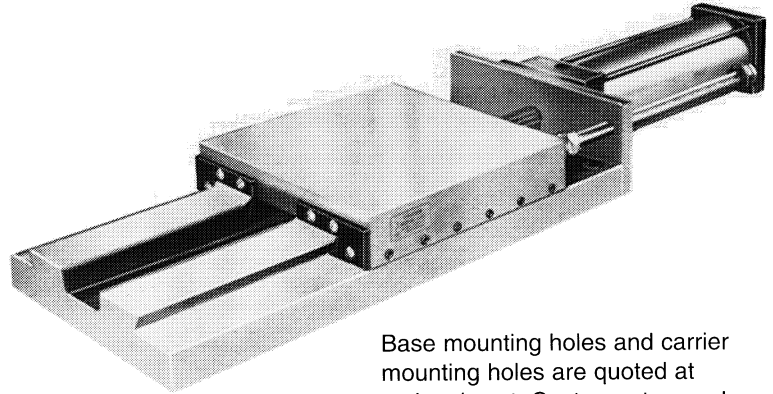

Base mounting holes and carrier mounting holes are quoted at optional cost. Customer to supply dimensional data.

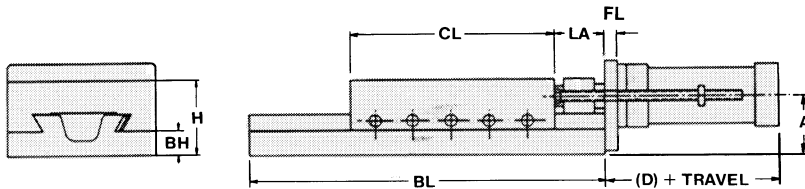
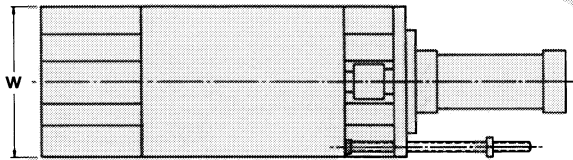

HAND FLAKED AS A STANDARD

WAY WIPERS ARE OPTIONAL

Model Number	D	Slide Width		DIMENSIONS IN INCHES								Bore Size	
		W	H	FL	BH	CL Max.	BL Max.	LA	A	AC	HC		
										AC	HC		
RB-4	AC	4½	4"	2¼	½	7/8	36	60	2⅞	1⅞	2.00	1.50	
	HC	4½											
RB-6	AC	4⅝	6"	3	½	1	36	72	2⅞	2⅝ ₁₆	2.50	1.50	
	HC	4½											
RB-8	AC	5⅜	8"	3¼	½	1¼	36	72	2½	2⅝	3.25	2.00	
	HC	4½											
RB-10	AC	5⅝	10"	3¾	¾	1⅝ ₁₆	36	72	2½	2⅝	4.00	2.00	
	HC	4¾											
RB-12	AC	5⅞	12"	4	¾	1⅞ ₁₆	36	72	2½	3	5.00	2.50	
	HC	4⅞											
RB-16	AC	5⅞	16"	5	¾	1¾	60	100	3	3⅞	6.00	3.25	
	HC	5⅞ ₁₆											
RB-20	AC	6½	20"	6	¾	2⅞	60	100	3	4⅞	6.00	4.00	
	HC	5⅞ ₁₆											
RB-24	AC	6½	24"	7	1	2½	60	100	3	5¾	6.00	5.00	
	HC	4⅞											

AIR CYLINDER POWERED

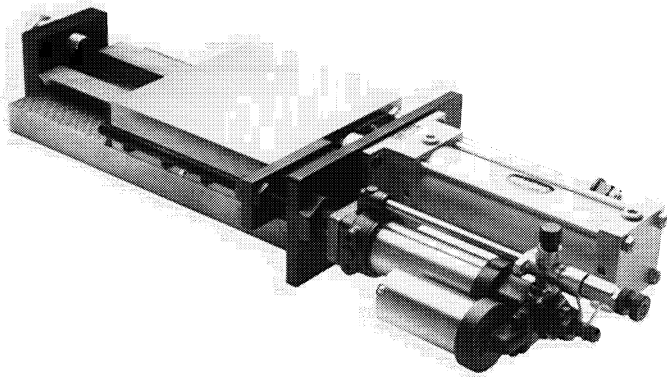

WITH HYDRAULIC CHECK CONTROL VALVE

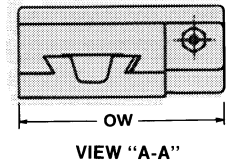

HEAVY DUTY AIR CYLINDER POWERED MACHINE SLIDES WITH HYDRAULIC CHECK AND CONTROL VALVE

These heavy duty machine slide assemblies are powered by the action of an air cylinder for rapid approach to desired working range of the unit. The rate of approaching speed may be controlled with an added easily installed control valve. Several types of valves for air cylinder control may be obtained.

These air cylinder powered units are provided with hydraulic control. At the desired (pre-determined) phase or point of action the hydraulic check valve can be set **to control rate of feed**. Air cylinder source of power for speed has greater advantages, whereas for a precise feed action hydraulic non-compressible oil assures uniformity, accuracy and smoothness if needed.

SMOOTH AND PRECISE ACTION

The extra heavy rigid base supports these controlling elements and assures best possible smoothness and precise action **over the entire working range**.

ALL MODELS ARE HAND FLAKED

Micro switch controls are also available

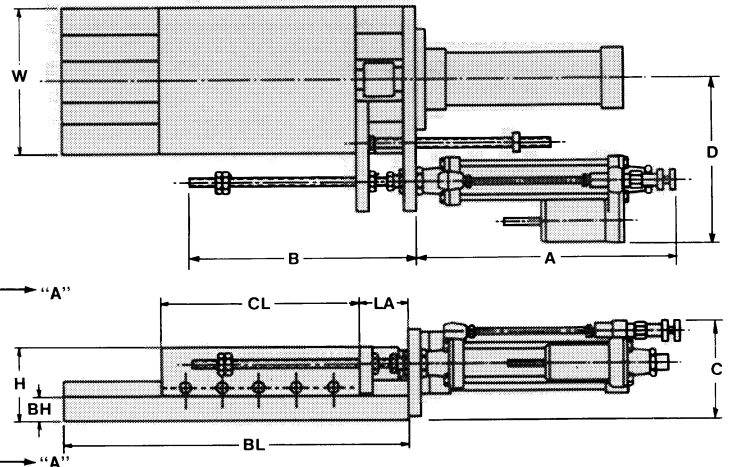

For more detailed information, or if your special needs are not answered by the illustrations shown, we suggest you tell us about your particular problem . . . **chances are we may have the answer for you.**

Hydro-Check Stroke							
STROKE	2"	4"	6"	9"	12"	15"	18"
DIM							
A	8.50	10.50	12.50	15.50	18.50	21.50	24.50
B	10.50	10.50	10.50	10.50	13.50	16.50	19.50

WAY WIPERS ARE OPTIONAL

Model Number	Slide Width		DIMENSIONS IN INCHES						
	W	OW	H	C	BH	CL,Max.	BL,Max.	LA	D
RB-4-AC-C	4"	8 ¹ / ₁₆	2 ¹ / ₄	3 ⁹ / ₁₆	7 ⁷ / ₈	36	60	2 ¹ / ₈	6 ¹ / ₁₆
RB-6-AC-C	6"	9 ⁹ / ₁₆	3	4	1	36	72	2 ¹ / ₈	6 ⁹ / ₁₆
RB-8-AC-C	8"	11 ⁷ / ₈	3 ³ / ₄	4 ¹ / ₄	1 ¹ / ₄	36	72	2 ¹ / ₂	7 ⁷ / ₈
RB-10-AC-C	10"	14 ⁹ / ₁₆	3 ³ / ₄	4 ⁵ / ₁₆	1 ⁵ / ₁₆	36	72	2 ¹ / ₂	9 ⁹ / ₁₆
RB-12-AC-C	12"	15 ¹ / ₂	4	4 ¹ / ₁₆	1 ⁹ / ₁₆	36	72	2 ¹ / ₂	9 ¹³ / ₁₆
RB-16-AC-C	16"	19 ¹ / ₂	5	6 ⁵ / ₁₆	1 ³ / ₄	60	100	3	11 ¹³ / ₁₆
RB-20-AC-C	20"	23 ⁹ / ₁₆	6	7	2 ¹ / ₈	60	100	3	13 ⁹ / ₁₆
RB-24-AC-C	24"	27 ¹ / ₂	7	8 ¹ / ₂	2 ¹ / ₂	60	100	3	15 ¹³ / ₁₆

Forward Feed, Reverse Feed, Double Feed, Skip Feed, Stop Feed, Skip and Stop Feeds
 Minimum Speed 4 In./Minute Maximum Speed 400 In./Minute
 Feed Control Unit Can Be Independently Mounted, Parallel Coupled or Tandem Coupled



HEAVY DUTY BASIC STYLE MACHINE SLIDES

Heavy Duty Basic slides are useful for a broad range of applications where the nature of the work to be done requires a more rugged construction than the Regular Duty slide assemblies. Greater stability and capacity are accomplished by increasing the thickness of the carrier and base. The increased height of the carrier also allows greater flexibility for machining mounting requirements.

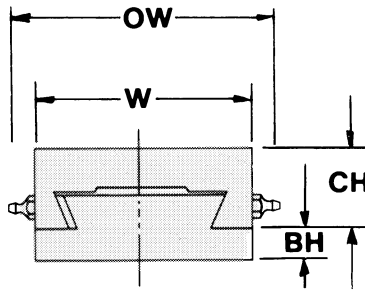
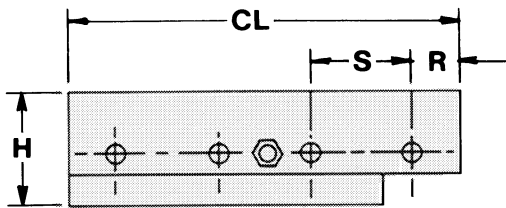
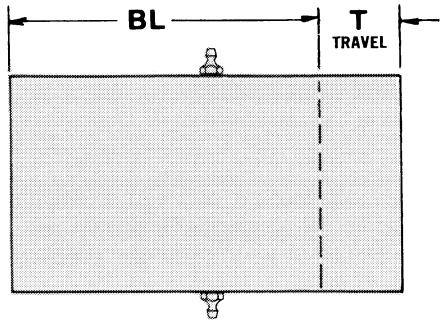
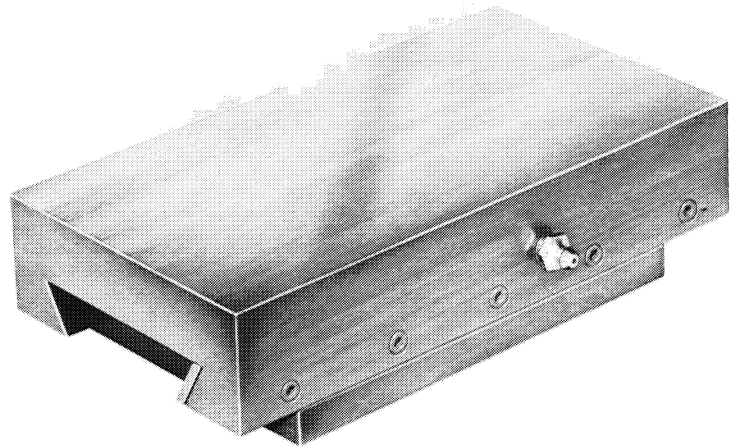

GIB LOCK HANDLE AVAILABLE AT ADDITIONAL COST

WAY WIPERS ARE OPTIONAL

Model Number	Slide Width	DIMENSIONS IN INCHES							Gib Screws	Gib Screw Spacing		Weight (lbs.)
	W	T	OW	H	BH	CH	CL	BL		S	R	
H468	4"	2	4 ^{13/16}	2 ^{1/8}	3/4	1 ^{3/8}	8	6	5	1 ^{1/8}	3/4	15 ^{3/4}
H4812		4	4 ^{13/16}	2 ^{1/8}	3/4	1 ^{3/8}	12	8	7	1 ^{11/16}	1 ^{5/16}	22
H6812	6"	4	6 ^{13/16}	2 ^{7/8}	7/8	2	12	8	7	1 ^{11/16}	1 ^{5/16}	46
H61016		6	6 ^{13/16}	2 ^{7/8}	7/8	2	16	10	9	1 ^{13/16}	3/4	60
H81218	8"	6	8 ^{13/16}	3 ^{1/8}	1 ^{1/8}	2	18	12	9	2	1	97
H81624		8	8 ^{13/16}	3 ^{1/8}	1 ^{1/8}	2	24	16	12	2	1	130

LUBRICATION — Provision is made for lubrication on all sizes of heavy duty slides.

HEAVY DUTY BASIC STYLE



SLIDE PROFILES

Full Scale

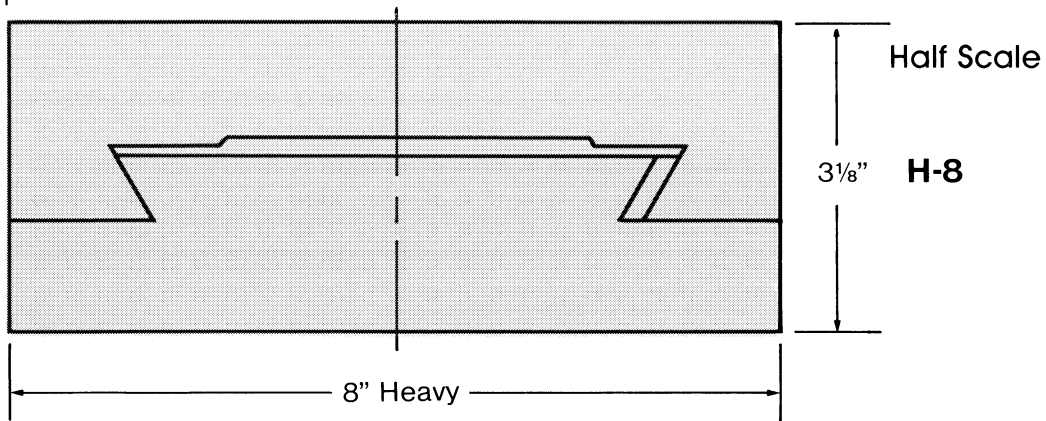
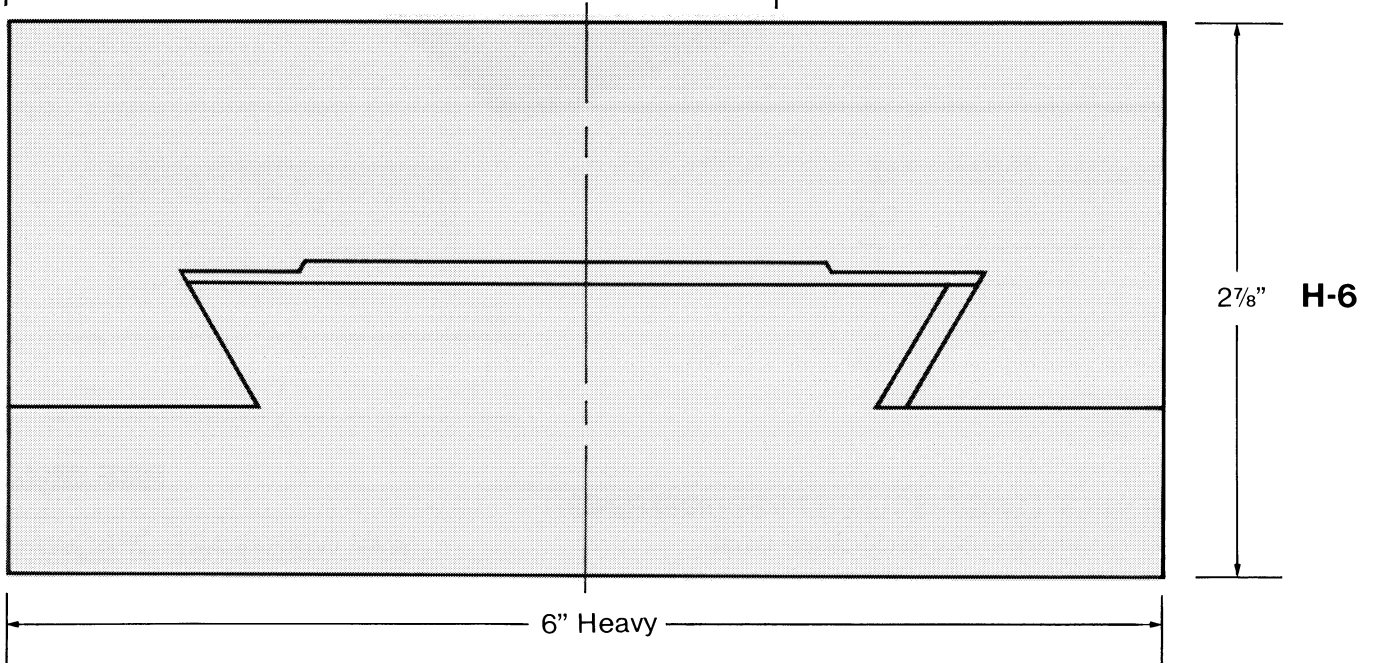
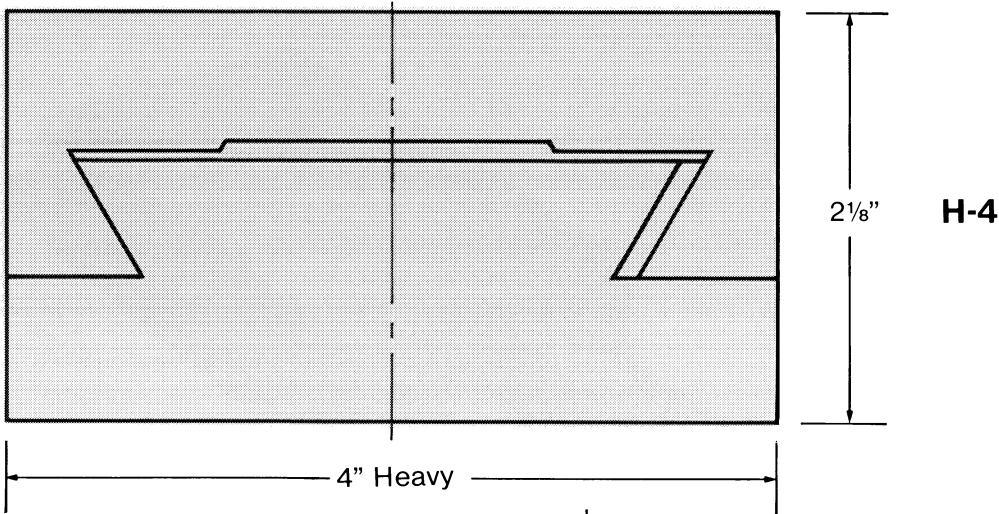



HEAVY DUTY RECESSED BASE MACHINE SLIDES

These slide assemblies feature versatility because of their availability in any incremental length. The recessed design in the base of the slide makes it possible to install a carrier drive inside the slide base. This permits a more compact design when mounting ball screws and air or hydraulic cylinder rods. The cavity also reduces the weight of the assembly.

Inquiries for special uses of power driven recessed base type slides are invited.

FLANGE BASE

Heavy Duty Recessed Base Machine Slides are also available with a mounting flange. RBF style slides (shown in diagram) are appropriate for many portable uses. They are available in the same sizes as RB style slides.

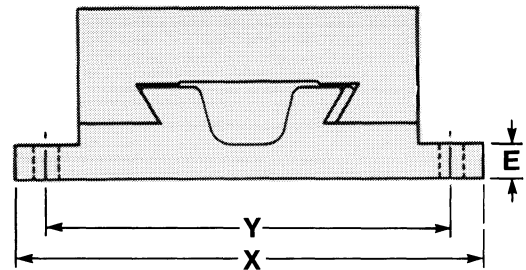
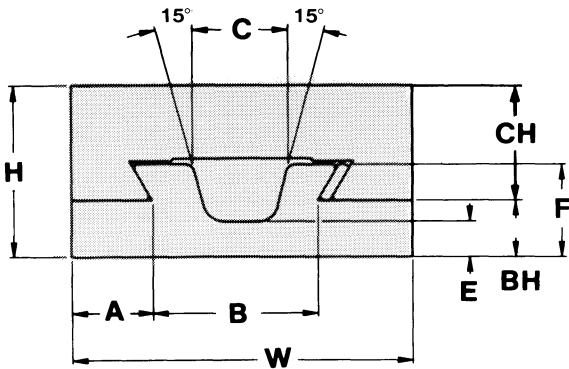
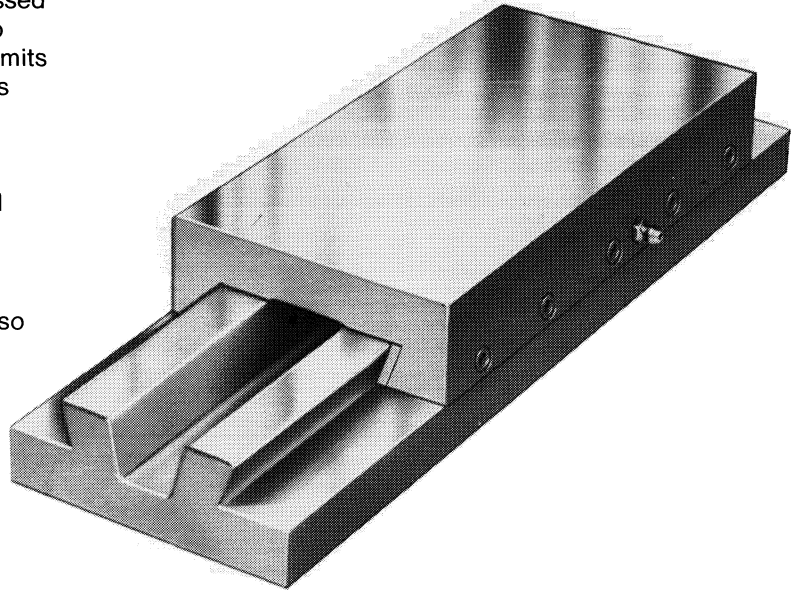

RBF Style

ANY COMBINATION OF LENGTHS TO SUIT REQUIREMENTS
Gib lock handle available at additional cost

WAY WIPERS ARE OPTIONAL

Model Number	Slide Width	DIMENSIONS IN INCHES											Weight in LB./IN. Length		
		W	H	C	E	BH	Max. CL	Max. BL	X	Y	F	A	B	MTG. Hole	WC
RB-3	3"	1 1/4	1	1/2	3/4	18	30	5 1/2	4 1/4	1 1/8	5/16	12 23/32	1 1/32	0.6	0.8
RB-4	4"	2 1/4	1 1/8	5/8	7/8	36	60	6 1/2	5 1/4	1 1/2	1 1/16	1 1 1/16	1 1/32	1.0	1.1
RB-6	6"	3	1 1/8	3/4	1	36	72	9	7 1/2	1 3/8	1 1/16	2 1 1/16	1 3/32	1.7	2.6
RB-8	8"	3 3/4	2	7/8	1 1/4	36	72	11	9 1/2	2	1 1/8	4	1 3/32	3.0	3.2
RB-10	10"	3 3/4	3 3/4	1 1/16	1 1/16	36	72	13	11 1/2	2 1/8	1 1/8	6 1/16	1 7/32	3.9	5.1
RB-12	12"	4	3 1/2	1 1/16	1 1/16	36	72	16	14	2 3/8	2 1/16	7 3/8	1 7/32	5.5	5.7
RB-16	16"	5	4 3/8	1 1/8	1 1/4	60	100	20	18	3 1/8	3 1/16	9 1/2	1 1/16	8.9	10.0
RB-20	20"	6	5 1/2	1 1/4	2 1/8	60	100	25	22 1/2	3 3/4	4 1/16	11 1/16	1 1/16	13.6	15.0
RB-24	24"	7	6	2	2 1/2	60	100	30	27	4 1/2	5 1/16	12 3/8	1 1/16	18.5	20.8

$H - BH = CH$

LUBRICATION — Provision is made for lubrication on all sizes of heavy duty slides.

HEAVY DUTY LEAD SCREW

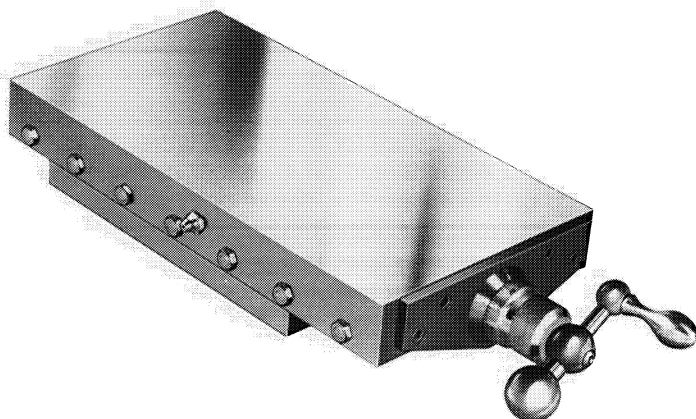

HEAVY DUTY LEAD SCREW MACHINE SLIDES
 MILWAUKEE SLIDE AND SPINDLE Heavy Duty Lead Screw slide assemblies, with their rugged construction and extremely heavy sectional profiles, are most useful in precise movement and feeding mounted tools or fixtures into working range. They assure best possible slide positioning, freedom of movement under heavy loads, and moderate overhang with little, if any, deflection.

These slide assemblies are available in a balanced crankhandle construction for control of slide movement by micrometer dial settings (assuring highly accurate positioning). For fine adjustment, a knurled knob component is available, which is very useful for conveniently adjusting to desired settings.

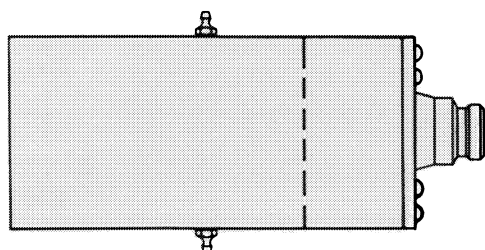

Style "B"
(Knurled Knob)

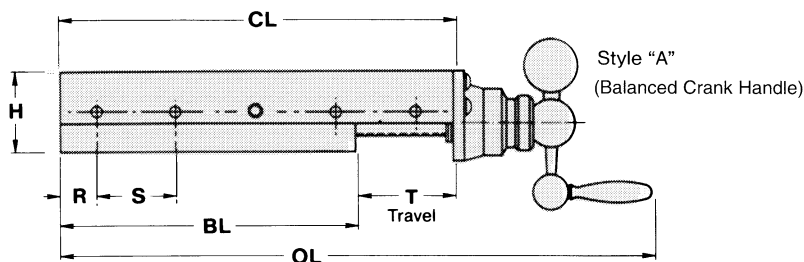

Style "A"
(Balanced Crank Handle)

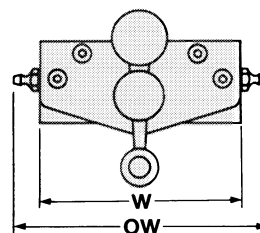

GIB LOCK HANDLE AVAILABLE AT ADDITIONAL COST

WAY WIPERS ARE OPTIONAL

Model Number	Slide Width	DIMENSIONS IN INCHES								Gib Screws	Gib Screw Spacing		Thread	Est. Weight (lbs.)
		W	T	OW	H	BH	CH	CL	BL		OL	S		
H4-6-8-L	4"	2	4 ¹³ / ₁₆	2 ⁷ / ₈	3/ ₄	1 ¹ / ₂	8	6	11 ⁷ / ₈	5	2	1	1/2-20 Vee-Type or 1/2-10 Acme	16 ¹ / ₂
H4-8-12-L		4	4 ¹³ / ₁₆	2 ⁷ / ₈	3/ ₄	1 ¹ / ₂	12	8	15 ⁷ / ₈	7	2	1		22 ³ / ₄
H6-8-12-L	6"	4	6 ¹³ / ₁₆	2 ⁷ / ₈	7/ ₈	2	12	8	16 ⁷ / ₈	7	2	1	3/8-20 Vee-Type or 3/8-10 Acme	48
H6-10-16-L		6	6 ¹³ / ₁₆	2 ⁷ / ₈	7/ ₈	2	16	10	20 ⁷ / ₈	9	2	1		62 ¹ / ₂
H8-12-18-L	8"	6	8 ¹³ / ₁₆	3 ³ / ₈	1 ¹ / ₈	2	18	12	23 ¹ / ₁₆	9	2	1	1/2-20 Vee-Type or 1/2-10 Acme	103
H8-16-24-L		8	8 ¹³ / ₁₆	3 ³ / ₈	1 ¹ / ₈	2	24	16	29 ¹ / ₁₆	12	2	1		145

LUBRICATION — Provision is made for lubrication on all sizes of heavy duty slides.
 Acme thread available at reasonable extra cost, on all models.



**MILWAUKEE
SLIDE AND
SPINDLE**

RECESSED BASE LEAD SCREW

HEAVY DUTY

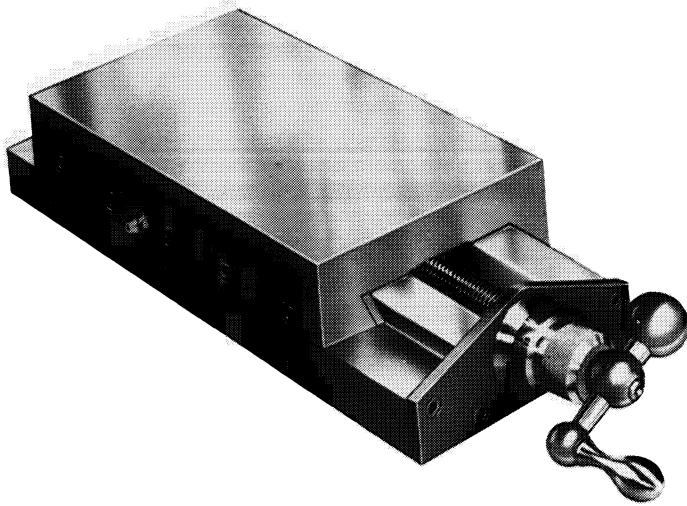

HEAVY DUTY RECESSED BASE LEAD SCREW MACHINE SLIDES

The MILWAUKEE SLIDE AND SPINDLE recessed base slide provides space for a lead screw having either a Vee or Acme thread on 4" and 6" slides. Acme is standard on the others. For higher loads and/or longer carrier travel, the Acme thread is recommended. Multiple carriers on one base that move either away or toward each other are possible by using a lead with R.H. and L.H. threads. Many other variations are also possible. Please consult our sales department for special applications.

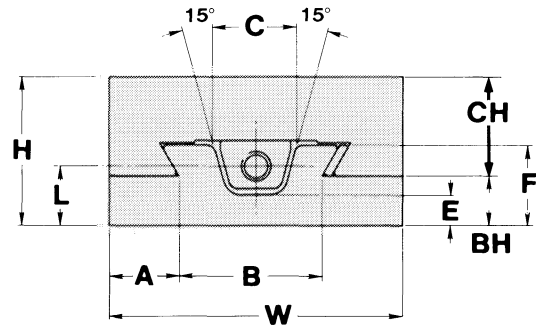

ANY COMBINATION OF LENGTHS TO SUIT REQUIREMENTS
Specify if required for inverted use

$H - BH = CH$ WAY WIPERS ARE OPTIONAL

Model Number	Slide Width	DIMENSIONS IN INCHES										Thread
	W	H	C	E	BH	Max. CL	Max. BL	F	A	B	L	TH
RB-3-L	3"	1¾	1	7/16	¾	18	30	1½	9/16	12 ³ / ₃₂	7/8	5/16-40 Vee
RB-4-L	4"	2¼	1 ⁵ / ₁₆	½	7/8	36	60	1½	1 ⁵ / ₁₆	1 ¹⁵ / ₁₆	1¼	½-20 Vee or ½-10 Acme
RB-6-L	6"	3	1 ¹¹ / ₁₆	5/8	1	36	72	1 ⁵ / ₈	1 ¹¹ / ₁₆	2 ¹⁵ / ₁₆	1¼	5/8-20 Vee or 5/8-10 Acme
RB-8-L	8"	3¼	2	7/8	1¼	36	72	2	2 ¹ / ₈	4	1 ⁵ / ₈	¾-10 Acme
RB-10-L	10"	3¾	3¼	1 ⁵ / ₁₆	1 ⁵ / ₁₆	36	72	2 ¹ / ₈	2 ¹ / ₈	6 ¹ / ₁₆	1 ⁵ / ₈	1"-10 Acme
RB-12-L	12"	4	3½	1 ³ / ₁₆	1 ⁹ / ₁₆	36	72	2 ³ / ₈	2 ⁷ / ₁₆	7 ³ / ₈	1 ⁷ / ₈	1"-10 Acme
RB-16-L	16"	5	4 ³ / ₈	1 ³ / ₈	1¼	60	100	3 ¹ / ₈	3 ¹³ / ₁₆	8 ⁹ / ₁₆	2 ³ / ₈	1¼"-10 Acme
RB-20-L	20"	6	5½	1¾	2 ¹ / ₈	60	100	3¾	4¼	11¾	3	1¼"-10 Acme
RB-24-L	24"	7	6	2	2½	60	100	4½	5 ¹⁵ / ₁₆	12 ³ / ₈	3¾	1½"-10 Acme

IPM DOVETAIL SLIDES



IPM DOVETAIL MACHINE SLIDES

IPM slide assemblies are versatile because of their availability in any inch increments of carrier and base length. This means the designer can use a slide to meet his specific length requirements, which often means a savings in cost and space.

Basic slide assemblies are manufactured with a longitudinal cavity in the base, permitting a more compact design when mounting the carrier drive. The cavity also reduces the weight of the assembly. In some applications, a base without the cavity may be advantageous because of the nature of the forces applied or certain mounting requirements.

IPM bases 8-16 have cored pockets as standard to reduce weight. Gib lock handles provide an easy way to lock the carrier in a desired position. For convenience on all sizes, the lock handles may be adjusted to lock in different angular positions.

Way surfaces can be supplied either milled, ground or scraped.

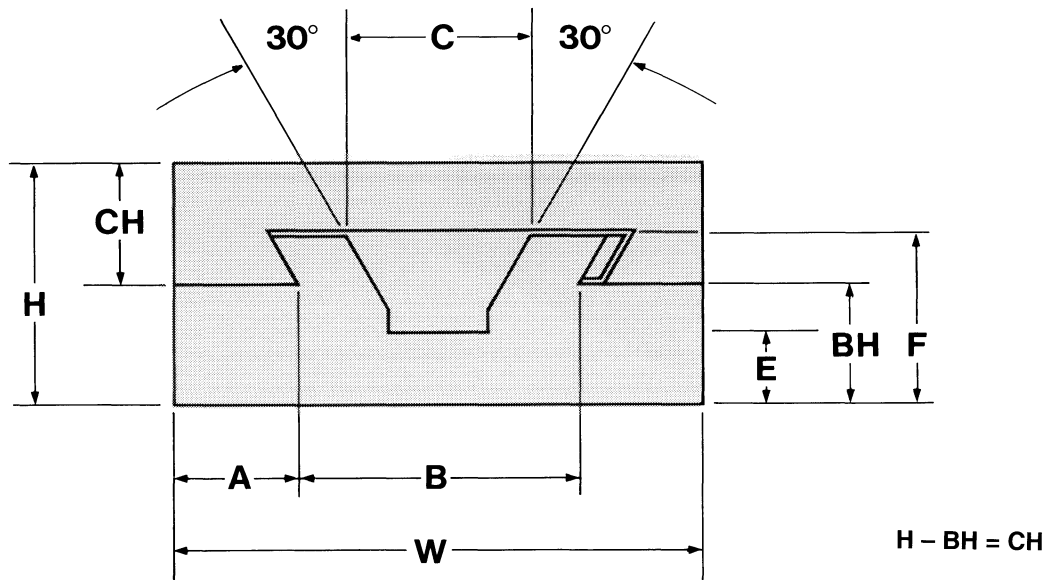

ANY COMBINATION OF LENGTHS TO SUIT REQUIREMENTS

WAY WIPERS ARE OPTIONAL

Model Number	Slide Width		DIMENSIONS IN INCHES									Thread
	W	H	C	E	BH	Max. CL	Max. BL	F	A	B	L	TH
IPM-2	2"	1 ⁵ / ₁₆	—	—	5 ¹ / ₁₆	14	12	5 ⁵ / ₈	1 ¹ / ₂	6 ¹ / ₆₄	5 ¹ / ₁₆	3 ³ / ₈ - 16 V
IPM-3	3"	1 ¹ / ₄	—	—	7 ¹ / ₁₆	18	18	55 ⁵ / ₆₄	3 ³ / ₄	125 ⁵ / ₆₄	7 ¹ / ₁₆	1 ¹ / ₂ - 10 A
IPM-4	4"	2 ¹ / ₄	1 ¹¹ / ₁₆	5 ⁵ / ₈	1 ¹ / ₁₆	24	24	19 ¹ / ₁₆	13 ¹ / ₁₆	2 ¹ / ₄	1 ¹ / ₃₂	3 ³ / ₄ - 10 A
IPM-6	6"	3	1 ⁷ / ₈	1 ⁵ / ₁₆	17 ¹ / ₁₆	24	36	2 ¹ / ₈	1 ¹¹ / ₆₄	3 ¹ / ₂	1 ⁵ / ₈	7 ⁷ / ₈ - 6 A
IPM-8	8"	4	3 ³ / ₄	1 ¹ / ₈	2	18	60	2 ⁷ / ₈	143 ⁵ / ₆₄	429 ⁵ / ₆₄	2 ³ / ₁₆	1 ¹ / ₄ - 5 A
IPM-10	10"	5	4 ¹ / ₃₂	13 ³ / ₈	2 ¹ / ₂	18	163	39 ¹ / ₁₆	2 ¹ / ₃₂	52 ¹ / ₃₂	2 ⁷ / ₈	1 ¹ / ₄ - 5 A
IPM-14	14"	6	4 ²⁷ / ₃₂	19 ¹ / ₁₆	3 ³ / ₄	36	194	4 ¹ / ₂	3 ¹ / ₁₆	729 ⁵ / ₆₄	3 ⁷ / ₁₆	2 - 4 A
IPM-16	16"	7	5 ¹ / ₂	2 ⁵ / ₈	3 ³ / ₄	72	122	5 ¹ / ₄	3 ¹ / ₂	8 ¹ / ₂	4 ¹ / ₄	2 - 4 A

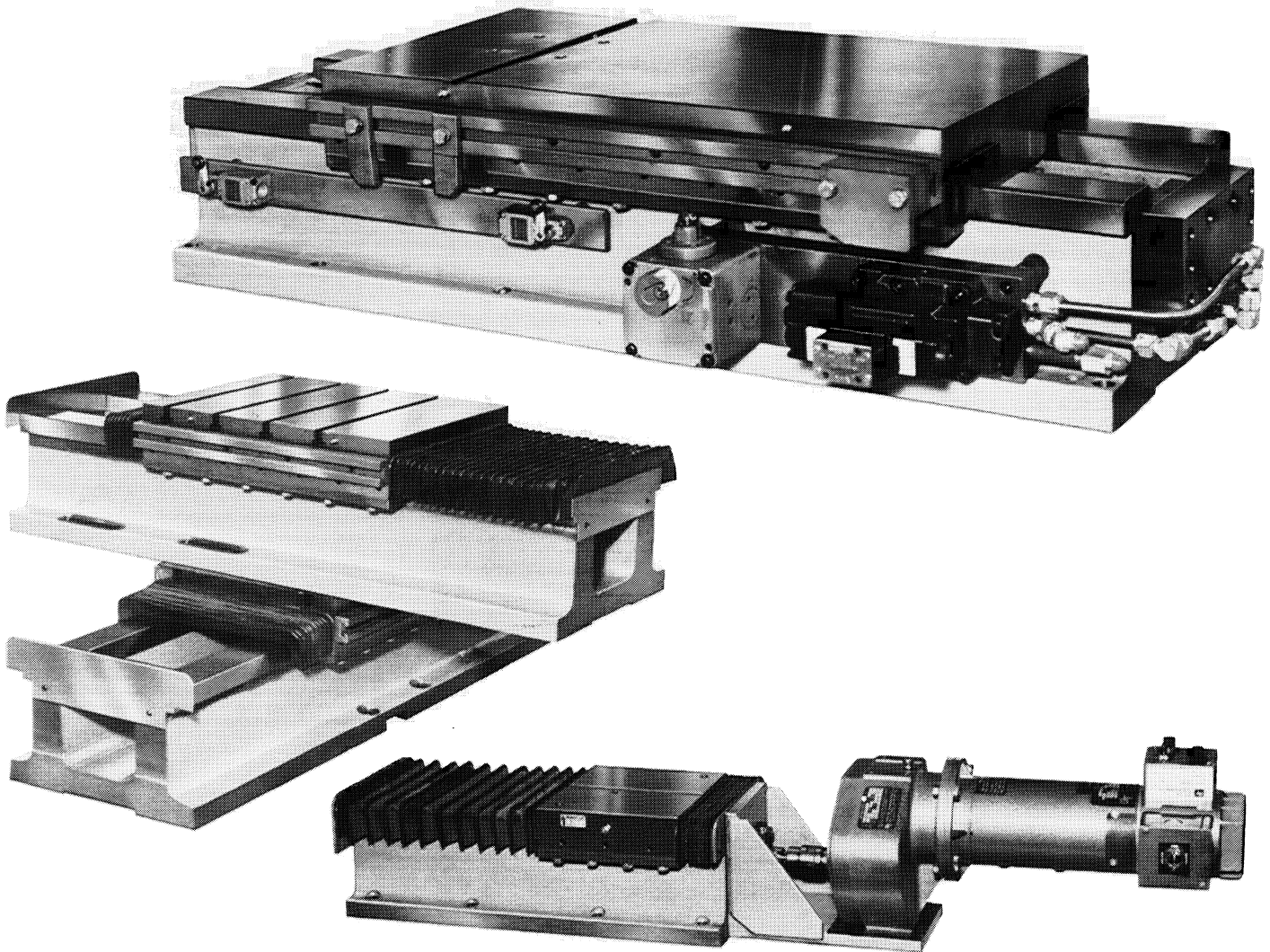

CONSTRUCTION FEATURES

- Model 7-9-12-15-18-24 & 32 inches wide.
- 40,000 PSI Close Grained Cast Iron Normalized.
- Casting lengths to 108 inches.
- Straight Gibs are standard in Carrier & Keepers.
- Tapered Gibs available in Carrier & Keepers.
- Hardened Rails to 58/60 Rockwell C.
- Lubrication provided to necessary areas.
- Ball Screws available with assorted motor drives.
- Hydraulic Cylinders & Hydraulic Components available, Limit Switches, Trip Pawls, Cam Rails, Decel & Speed Control valves, etc.
- Way Wipers are standard accessories, while Accordion Way Protectors are available as optional.
- Low Profile Slides for special needs.
- Large slide assemblies inspected with laser for precision.
- Engineering can be provided for all your custom needs — Electrical, Mechanical, Hydraulic & Pneumatic.
- Non-galling, antifriction bearing material (optional)

HARDENED STEEL WAYS

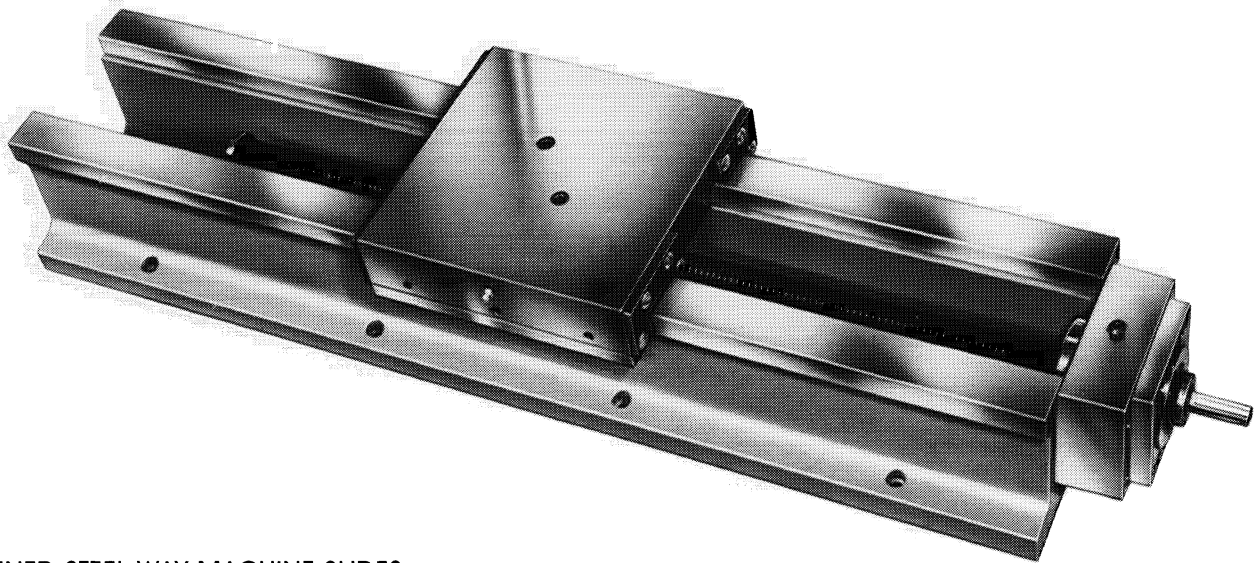

HARDENED STEEL WAY MACHINE SLIDES

The carrier of fine grain metal provides high strength and minimizes distortion. This heavy, rugged base structure is designed to carry greater loads than conventional dovetail types. These slides can be fitted with JIC mounted cylinder controls, flow control valve, deceleration valve, four way control valve, adjustable positive stop, limit switches and trip pawls.

Any number of suitable saddle and base combinations are available to extend the range of application on this heavy load carrier slide in base lengths ranging up to a maximum of 108".

This type of slide permits installation of electric cycle controls and other optional auxiliary equipment. The open center structure in the base is suitable for lead screw or cylinder powered operation. Consult price sheet for these options and others available.

INCLUDING AS STANDARD

- Gibs in keepers
- Way wipers
- Mounting holes in base
- Lubrication to ways & drives

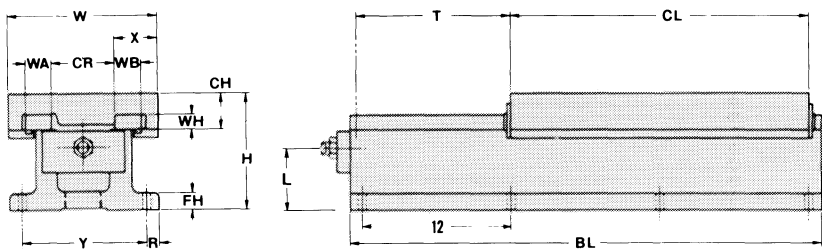

Carrier mounting holes are quoted at optional cost.

Model Number	Slide Width	DIMENSIONS IN INCHES											
	W	H	CR	WH	WA	WB	CH	FH	T-CL-BL	X	Y	R	MTG. Hole
HW7	7"	5.0	2.4	.64	1.50	1.73	.75	To your specs.	2.3	5.75	.625	1 ³ / ₃₂	2.2
HW9	9"	7.0	3.78	.90	1.60	2.05	1.0		2.61	7.5	.75	1 ⁷ / ₃₂	3.5
HW12	12"	10.0	4.88	1.15	2.16	2.5	1.3		3.56	10.5	.75	1 ⁷ / ₃₂	5.6
HW15	15"	11.5	6.5	1.30	2.60	2.85	1.4		4.25	13.0	1.0	1 ¹ / ₁₆	6.8
HW18	18"	13.0	8.0	1.53	3.25	3.2	1.6		5.0	16.0	1.0	1 ¹ / ₁₆	7.5
HW24	24"	15.0	11.0	2.00	4.00	3.75	1.8		6.5	22.0	1.0	1 ¹ / ₁₆	9.2
HW32	32"	15.0	18.5	1.90	4.38	4.95	2.0		6.75	30.0	1.0	1 ¹ / ₁₆	9.2

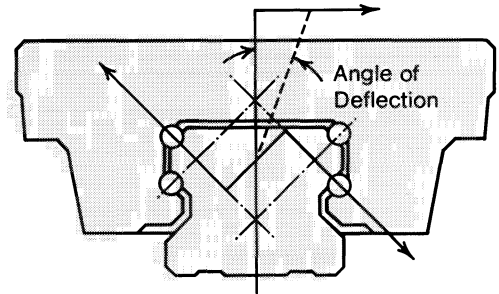
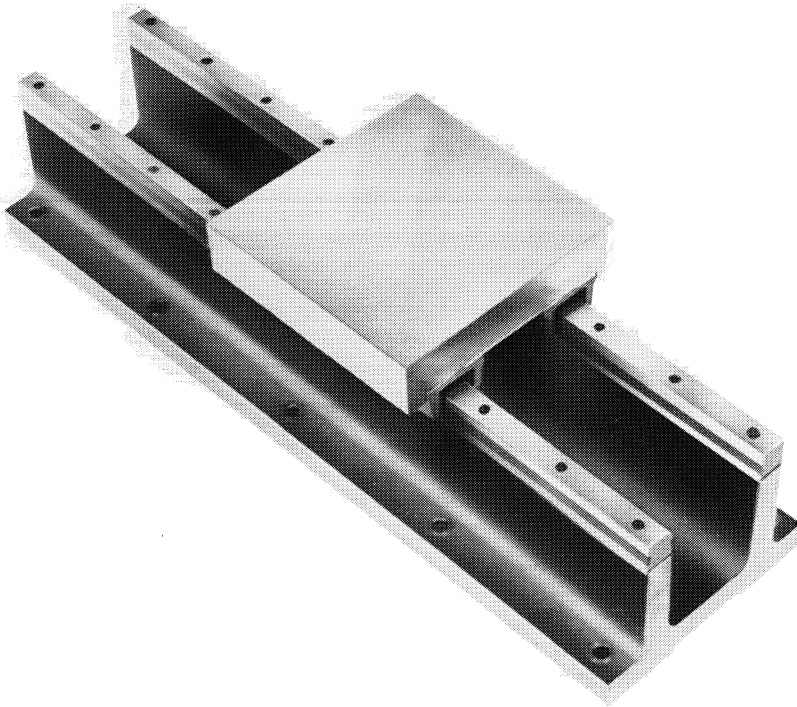

Figure 1. Older design: the angle of deflection is large under moment load.

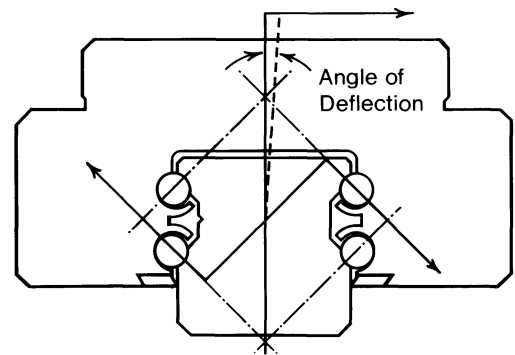

Figure 2. NEW Empirical design: the angle of deflection is small under moment load.

HIGH PRECISION RIGID LINEAR MOTION

Stay competitive in today's dynamic manufacturing market with MILWAUKEE SLIDE AND SPINDLE Recirculating Ball Way Slides. These state-of-the-art slides and linear guideways will greatly improve your machine or system productivity.

FEATURING:

- A high degree of control at low speed
- Low temperature operation at high speed
- A low driving force requiring 1/10 the force and 1/2 the electrical consumption of conventional linear slides
- Easy maintenance

MILWAUKEE SLIDE AND SPINDLE is a pioneer and leader in the research and development of high efficiency machine tool slide assemblies. Our precision rails with their rolling elements utilize a NEW design (fig. 2) which offers a more stable structure for withstanding moment loads. With this design, our Recirculating Ball Way Slides can deliver **INCREASED RIGIDITY** and **STABLE** high speed travel. The older

face-to-face design concept (fig. 1) would be hard pressed to meet the machine tool rigidity of the Empirical back-to-back design concept (fig. 2).

For applications requiring rigidity and precise, low-friction linear movement of heavy loads and moments, we offer standard models HB, HUB, HBL, HBR and HBS. Customized slides are also available.

The base and table are manufactured from high tensile close-grain cast iron, normalized for maximum stability. Other materials are also available such as steel, stainless steel and aluminum. The rolling elements and precision rails utilize MILWAUKEE SLIDE AND SPINDLE machine tool quality bearing products.

All models are available with precision ground ball screws, keyed shaft extensions and piloted mounting flange for power applications. Other types of drives or accessories similar to those used on dovetail and hardened steel way assemblies can be provided.

LOW PROFILE BALL SLIDE



LOW PROFILE BALL WAY MACHINE SLIDES

HUB - Low Profile slide assemblies are useful for many service applications where accurate high speed positioning or feeding is needed.

These slide assemblies feature versatility because of their availability in any incremental length. The most significant advantage of these units are the load carrying capacities, whereby the design loads can be applied in any direction to the table or base. All HUB assemblies are preloaded and specifically designed for vertical, inverted or horizontal applications.

We offer special tables or bases to meet customers' particular requirements. The base of the table may be drilled, tapped and counterbored for mounting screws. The table surface may be machined to accept various accessories, fixtures and equipment.

The illustration shown is fitted with a preloaded, precision ground, ball screw assembly.

CARRIER MOUNTING HOLES ARE QUOTED AT OPTIONAL COST.

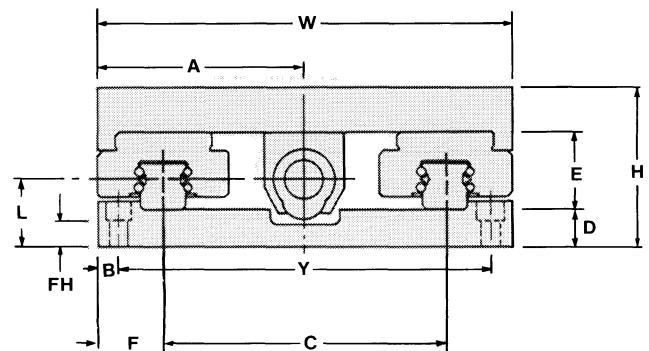
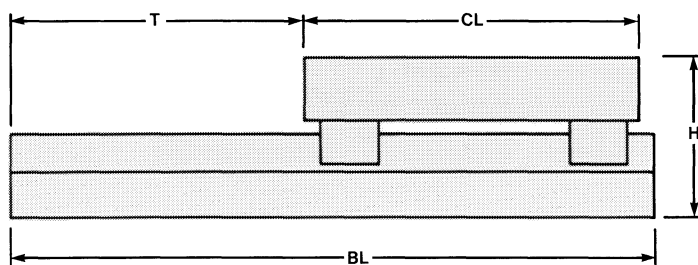

Model Number	Width		DIMENSIONS IN INCHES										Basic Load	
	W	H	C	E	FH	Y	F	D	A	B	L	MTG. Hole	Dynamic	Static
HUB-6	6"	3.00	3.16	.94	.75	4.90	1.42	1.03	3.00	.55	1.38	1 ¹ / ₂	1439	2261
HUB-8	8"	3.25	5.16	1.18	.75	6.56	1.42	1.03	4.00	.72	1.62	1 ¹ / ₂	3352	5072
HUB-10	10"	3.75	6.02	1.42	.81	8.36	1.99	1.17	5.00	.82	1.88	1 ¹ / ₂	7806	11378
HUB-12	12"	4.00	6.68	1.89	.75	9.96	2.66	1.06	6.00	1.02	2.00	1 ¹ / ₂	14641	20198
HUB-16	16"	5.00	9.74	2.36	.94	13.22	3.13	1.32	8.00	1.39	2.50	2 ¹ / ₂	23594	31620
HUB-20	20"	6.00	12.80	2.76	1.31	16.42	3.60	1.62	10.00	1.74	3.00	2 ¹ / ₂	34798	45423
HUB-24	24"	7.00	15.38	3.35	1.56	19.50	4.31	1.83	12.00	2.25	3.50	2 ¹ / ₂	27783	71000

Consult our engineering department for assistance when selecting a machine slide or linear guideway where overhung loads are applied and deflections are critical.

The most important characteristics required of any machine tool slide are precision and rigidity. Rigidity of the ball bearing linear guideways must be achieved either by preloading the bearings, or through Empirical design.

Additional preloading becomes necessary when the Old design (fig. 1, p. 18) is used. In this design, the contact angles converge inside the bearing. Application of a moment load will then result in a disproportionately high ball load and excessive deflection. Such conditions will shorten the life of the slide and decrease its accuracy.

With the Empirical design (fig. 2, p. 18) the contact angles converge outside of the outer race. This results

in a more stable structure with a much smaller angle of deflection.

Designers and machine builders know that imprecise mounting of linear guideways will reduce the accuracy of the work they produce. Linear motion bearings are, in principle, the same as rotary motion bearings. Rigidity, not flexibility, is required. The fact is, neither the old nor the new design concept will allow or compensate for improper mounting.

When using machine tool quality bearings, insist on machine tool quality bases and tables manufactured by MILWAUKEE SLIDE AND SPINDLE.

RECIRCULATING BALL WAY SLIDE LOADING EXAMPLE

Notes:

1. Minimum slide table length should be equal to the slide width.
2. Each slide assembly should have a minimum of 2 bearings per rail.
3. The basic load ratings on page 21 are applicable to HB and HUB slides of the same width.
4. Load ratings on page 21 can be applied in any direction.
5. Rated values shown are based on (4) bearings per slide assembly, one-fourth the total load is the capacity of each bearing.

MOMENT LOAD APPLICATION

PARAMETERS

Model HUB12-40-12

P = 600 lbs. drill force

l = 14 inches (moment)

LB = Bearing load

D = 6.7 inches

($\frac{1}{2}$ - $\frac{1}{2}$ BRG)

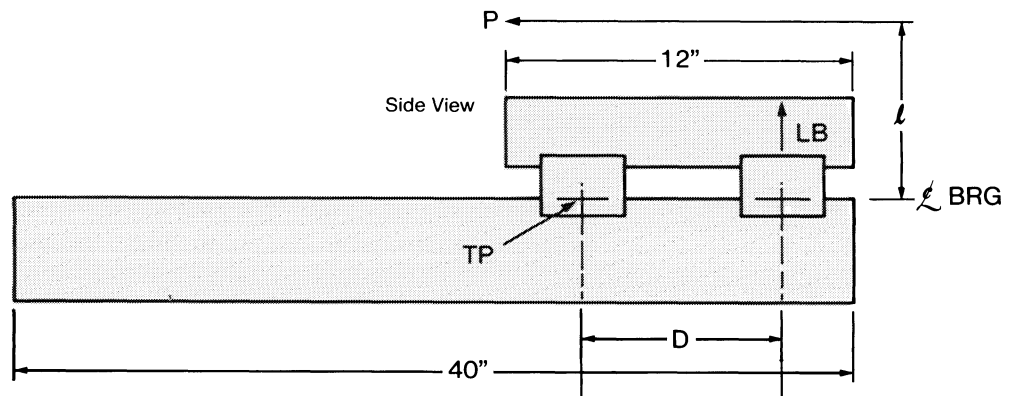
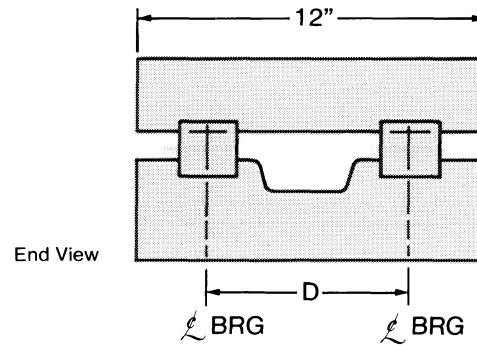

$$LB = \frac{P \times l}{(2) \text{ rails} \times D} = \text{lbs.}$$

$$LB = \frac{600 \times 14}{2 \times 6.7} = 627 \text{ lbs. per brg.}$$

MILWAUKEE SLIDE AND SPINDLE's HUB12 is rated at a static load of (20,000 x 1/4) pounds per bearing = 5,000 lbs.

Therefore, if we use the HUB12 model we have a factor of safety of $\left(\frac{5000}{627}\right) = 8$

HIGH PROFILE BALL SLIDE



HIGH PROFILE BALL WAY MACHINE SLIDES

HB-Deep base profile slide assemblies are designed to handle extra heavy horizontal applications for special purpose high production machines.

The deep base model features a recess between the ways. With this clearance in the center of the base, feed mechanisms may be buried. Typical feed mechanisms might be rodless air cylinders, standard air or hydraulic cylinders, rack and pinion drives, special ball screws and position feedback equipment. Clearance ports can be provided through each side of the deep base model to allow easy access for plumbing or electrical wiring.

HB Models carrying capacities range from 5,000 to 150,000 pounds, loads are assumed to be perpendicular, and evenly spread over the table assembly. Loads may be applied in any direction to the table, but care must be taken to assure that they are properly calculated. Special care should be taken with cantilevered loads.

The illustration shown is fitted with a*preloaded precision ground ball screw assembly.

CARRIER MOUNTING HOLES ARE QUOTED AT OPTIONAL COST.

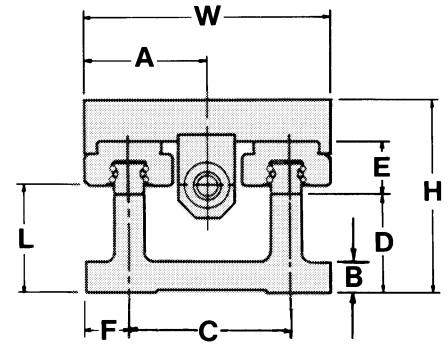
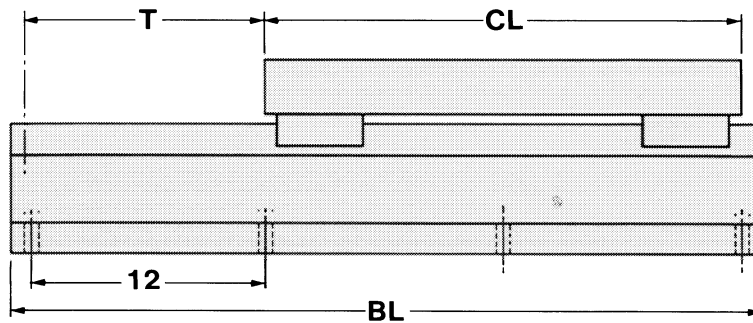

For mounting hole locations see p. 17

Model Number	Width	DIMENSIONS IN INCHES								Optional		
	W	H	C	E	F	D	A	B	L	Ho	Do	Lo
HB-7	7"	5.00	3.16	.94	1.42	3.06	3.50	.65	2.75	5.30	3.36	3.75
HB-9	9"	7.00	5.16	1.18	1.42	4.75	4.50	1.00	3.88	7.28	5.03	5.38
HB-12	12"	10.00	6.02	1.42	1.99	6.74	6.00	1.30	5.53	10.27	7.01	7.25
HB-15	15"	11.50	6.68	1.89	2.66	7.61	7.50	1.50	6.38	12.10	8.21	8.78
HB-18	18"	13.00	9.74	2.36	3.13	8.42	9.00	1.80	7.18	13.84	9.26	9.72
HB-24	24"	15.00	12.80	2.76	3.60	9.76	12.00	2.00	8.31	15.88	10.64	11.18
HB-32	32"	15.00	15.38	3.35	4.31	8.60	16.00	2.00	8.31	16.45	10.05	12.18

T-CL-BL available to your specifications

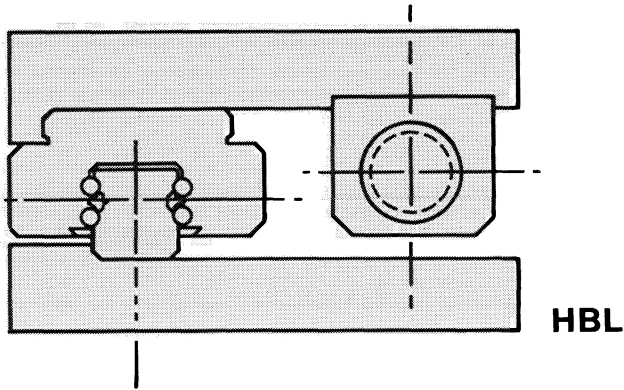

HBL

ALTERNATIVE PROFILES

The HBL, HBR and HBS have been the most popular of the various custom ball slides produced by MILWAUKEE SLIDE AND SPINDLE. Variations are available in widths from 6 inches to 60 inches and in lengths to suit your particular needs. For specific dimensions and loading characteristics, please consult our Application Engineering Department.

HBL BALL SLIDE ASSEMBLIES are the most economical ball way slides available with lead screw drive. They can be furnished with the handcrank or motor of your choice.

HBR BALL SLIDE ASSEMBLIES are primarily for gantry type machines and overhead robot arm applications.

HBS BALL SLIDE ASSEMBLIES are the **Milwaukee Super Slide** for extremely high moment loads. Axial load capacities can reach 1.5 million inch pounds of moment load.

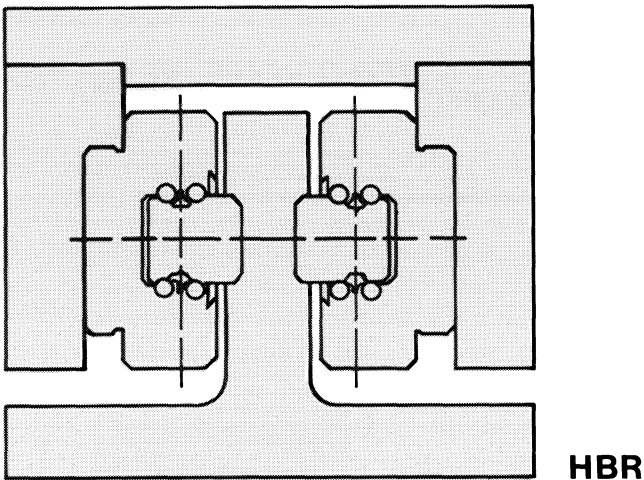

HBR

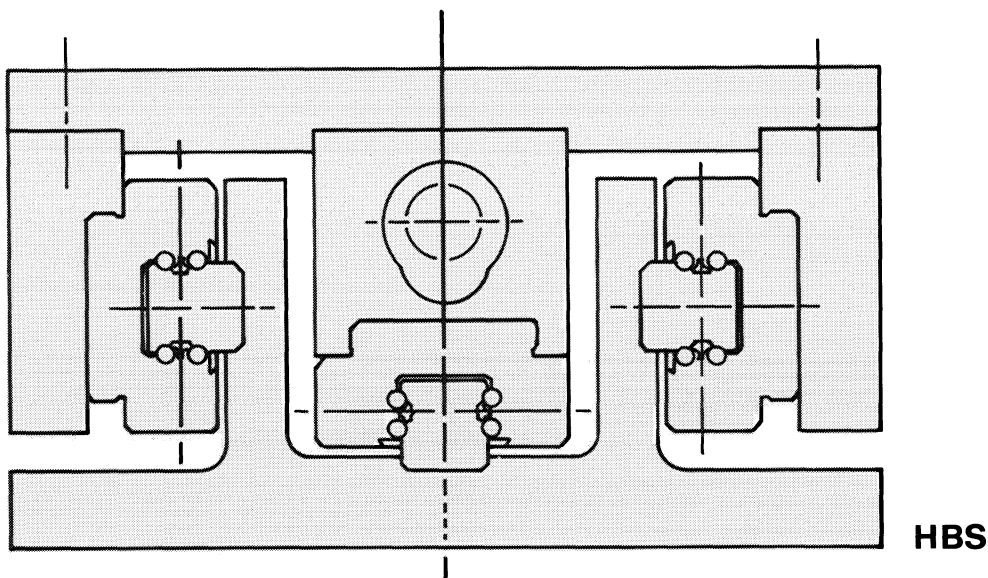

HBS

ANGLE PLATES AND SWIVELS

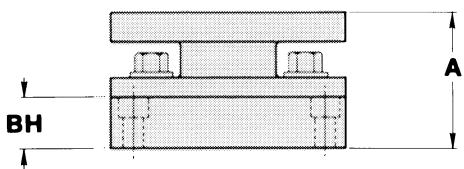
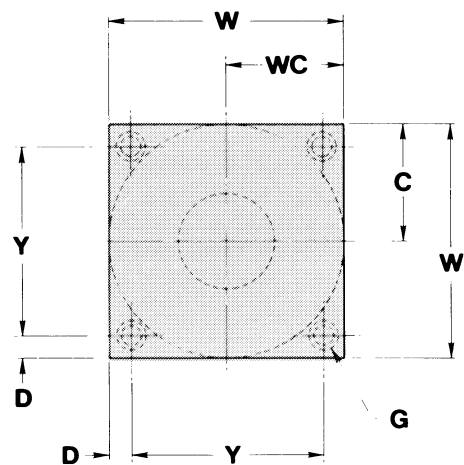
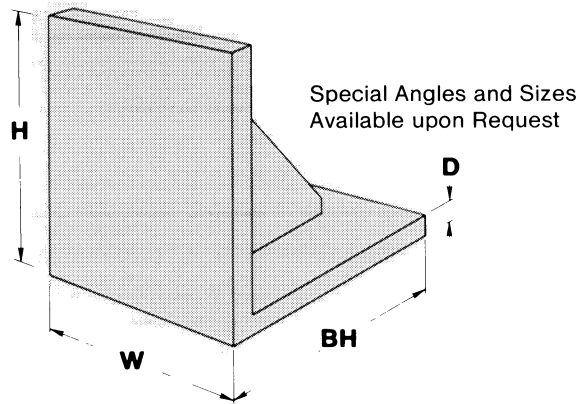

ANGLE PLATES

MOUNTING HOLES ARE QUOTED AT OPTIONAL COST.

Slide	W	H	BH	D
2"	2.00	3.00	2.00	.50
	2.00	4.00	2.00	.50
	2.00	6.00	4.00	.50
3"	3.00	4.00	3.00	.75
	3.00	5.00	3.00	.75
	3.00	6.00	4.00	.75
4"	4.00	6.00	4.00	.88
	4.00	8.00	4.00	.88
	4.00	10.00	6.00	.88
	4.00	12.00	6.75	1.00
6"	6.00	8.00	4.00	.88
	6.00	12.00	6.75	1.00
	6.00	16.00	8.75	1.00
8"	8.00	18.00	9.75	1.00
	8.00	24.00	13.00	1.00
10"	10.00	26.00	13.00	1.25
	10.00	30.00	15.00	1.25
12"	12.00	26.00	13.00	1.25

SWIVELS

BASE MOUNTING HOLES ARE STANDARD -
ADDITIONAL MOUNTING HOLES ARE QUOTED AT OPTIONAL COST.

Swivels	W	C	BH	Y	D	A	G
4"	4.00	2.00	.88	3.25	.38	2.31	(4) ⁵ / ₁₆ SCR.
6"	6.00	3.00	1.00	4.75	.62	2.50	(4) ³ / ₈ SCR.
8"	8.00	4.00	1.12	6.75	.62	3.00	(4) ¹ / ₂ SCR.
10"	10.00	5.00	1.12	8.50	.75	3.00	(4) ¹ / ₂ SCR.
12"	12.00	6.00	1.38	10.50	.75	3.50	(4) ⁵ / ₈ SCR.
16"	16.00	8.00	1.62	14.00	1.00	4.00	(4) ³ / ₄ SCR.
20"	20.00	10.00	1.62	17.00	1.50	4.50	(4) ³ / ₄ SCR.
24"	24.00	12.00	2.00	21.50	1.25	5.00	(4) 1" SCR.

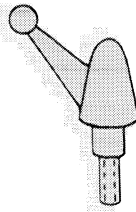

HANDLE GIB LOCKS

Easily repositioned handle gib locks can be furnished on all basic and lead screw type machine slides.

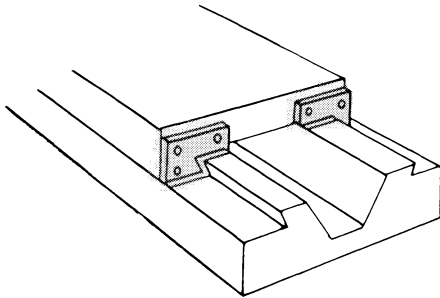

WAY WIPERS

In most applications, way wipers provide protection to way surfaces from chips and dirt. When using way wipers, 1" should be added to base length to ensure the wipers are always on the ways. Available on all sizes, except regular duty. Wipers are made of hard rubber. Standard on hardened way slides.

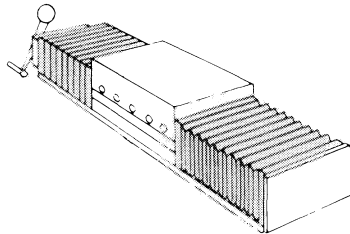

ACCORDION TYPE COVERS

If MILWAUKEE SLIDE AND SPINDLE slides are to be used where they will be exposed to abrasive materials or fine chips, the ways of the slide should be covered with a flexible accordion type cover. These are available in a variety of sizes. Specify the model of the slide when ordering a cover for the ways.

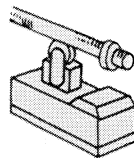

MICRO SWITCH CONTROLS

For synchronizing slide movements relative to solenoid operated control valves, a micro switch control rod assembly may be incorporated into these units . . . permits setting on any desired point of the entire slide movement.

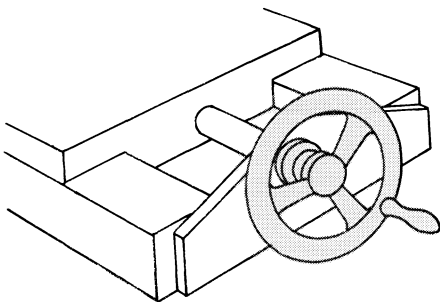

HANDWHEEL

For ease and speed in advancing and retracting carrier, handwheels are available. A micrometer dial allows zero reset for easy point to point adjustment.

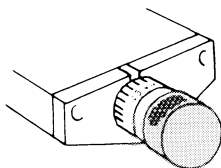

KNURLED KNOB

Knurled knob equipped machine slides offer a desirable feature for smooth and precise lead screw movement control.

STEEL COVERS

Steel covers are used when accordion type covers are not appropriate for chip loads.

TAPERED GIBS

Tapered gibs available at slight extra cost. Essential for accurate motion and wear compensation.

ANTI-BACKLASH NUTS

With a simple adjustment, the backlash in the lead screw can be reduced. Also, it can be used to compensate for wear in the lead screw nut.

T-SLOT SLIDES

T-slot slides are available on RB and H slides for mounting fixtures and production work. When ordering, please specify desired dimensions.

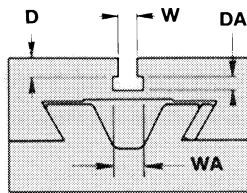

DRILL AND TAPPED OR C-BORED MOUNTING HOLES

These can be furnished in slides and swivels upon customer's request.

FLAME HARDENED WAYS

Flame hardened ways can be provided and are hardened to RC-38-44.

ELECTROLESS NICKEL PLATED WAYS

For reduction of friction and wear and increased corrosion resistance. Plating is RC-62 hardness.

RISER BLOCKS

Extremely useful for meeting engineering needs, riser blocks are available on all slides. Dimensions and mounting holes to be specified by customer.

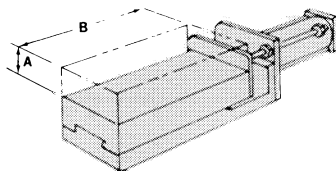

COMPOUND SLIDES

These slide assemblies consist of two slides for transverse and longitudinal movements. Can be mounted on a swivel base if desired.

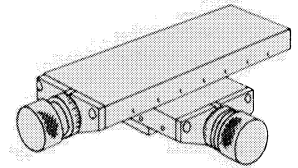

RIGHT ANGLE DRIVES

This compact design provides for easy adjustment where space is a critical factor. The hand wheel with control box can be mounted in any one of four positions, either as shown or with wheel in an up position, down position, or opposite as shown. Available for all RB, IPM, HW, HB and HUB lead screw models.

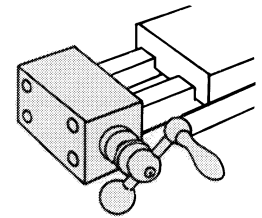

SINGLE/VARIABLE SPEED, MOTOR DRIVES

Any number of drives can be coupled to the lead screw. Let our engineering department study your requirements.

ONE SHOT AND AUTOMATIC LUBE SYSTEMS

For high cycle and high production, adequate lubrication is recommended. These systems replace standard pressure fittings.

BALL SCREW DRIVES

Ball screw drives are available in standard or special precision leads with pre-loaded zero backlash, double or standard ball nuts. Prices on request.

SPECIAL METALS

When special metals are desired in making your slides, these can be provided to fit your individual needs. Quotations for these special slides, made according to your specifications, will be furnished upon request.



ENGINEERING DATA

The following information should be used as a guide to determine the size of a Dovetail slide for your particular application.

COMPOSITION AND RESOLUTION OF FORCES

It is most important in all sliding applications to understand the loading conditions before selecting a particular slide.

To insure long, accurate life and an efficient sliding motion, it is recommended that the bearing surface pressure be limited from 50 to 60 pounds per square inch (psi), on engaged slide ways. However, if movement or sliding efficiency is not a factor, all loading limitations are determined from the mechanical and physical properties of the slide selected.

The following symbols are used in formulas for obtaining slide way stress and drive force/torque requirements.

- P** = Static load, in pounds
- WC** = Carrier weight, in pounds per inch of length
- F** = Force required to move load and/or overcome resistance, in pounds
- FR** = Resistance, actual force required to do work, in pounds
- M** = Moment of a force, is the product of Force multiplied by the perpendicular distance from a given point to the line of force, in inch pounds
- ℓ** = Perpendicular distance from a given point to the line of force, in inches
- LC** = Carrier length, in inches
- SP** = Maximum recommended slide way surface pressure 55 pounds per square inch (psi)
- u** = Coefficient of static friction
 - Ground cast iron with lubrication - .23
 - Ground Turcite with lubrication - .08
 - Ground PPS composite without lubrication - .18
- T** = Torque required at drive screw to move load and/or overcome resistance, in pounds
- PS** = Lead of drive screw thread, in inches
- e** = Lead screw efficiencies, in percentages
 - Ball nut - .85
 - Acme Metallic nut - .30
 - Acme PPS composite - .45
- TP** = Theoretical pivot, a given point, about which a force can produce rotation. Also termed as the center of moment.
- SA** = Engaged slide way surface area per inch of carrier
- ℓ₁** = Distance from TP to center line of slide way load bearing surface

EXAMPLES OF LOADING CONDITIONS

(All loads are uniformly distributed)

The following examples, formulas and calculations are based on the application of model RB10-20-10 (10 inch wide slide, 20 inch long base, 10 inch long carrier).

CASE NO.1

Vertical load on horizontally mounted slide

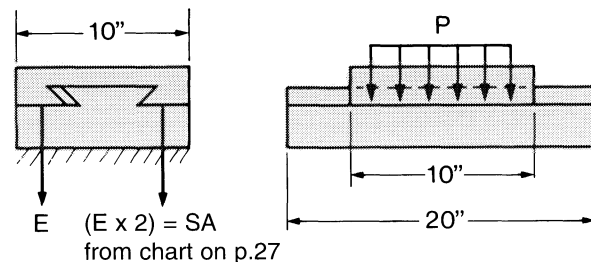

MAXIMUM RECOMMENDED LOAD

$$P = (SA \times LC \times SP) - (WC \times LC)$$

$$P = (3.6 \times 10 \times 55) - (3.9 \times 10) = 1941 \text{ lbs.}$$

CASE NO. 2

Vertical load on inverted horizontally mounted slide

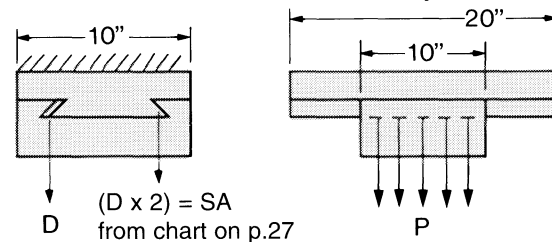

MAXIMUM RECOMMENDED LOAD

$$P = (SA \times LC \times SP) - (WC \times LC)$$

$$P = (.96 \times 10 \times 55) - (3.9 \times 10) = 489 \text{ lbs.}$$

CASE NO. 3

Vertical load on horizontally side mounted slide

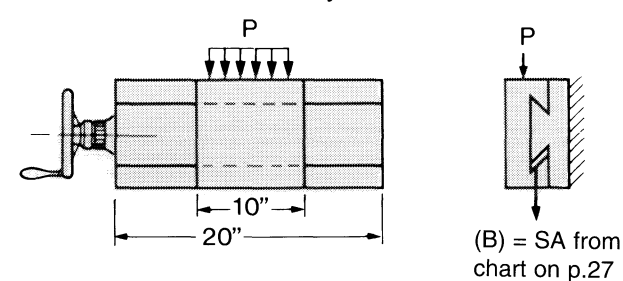

MAXIMUM RECOMMENDED LOAD

$$P = (SA \times LC \times SP) - (WC \times LC)$$

$$P = (.82 \times 10 \times 55) - (3.9 \times 10) = 412 \text{ lbs.}$$

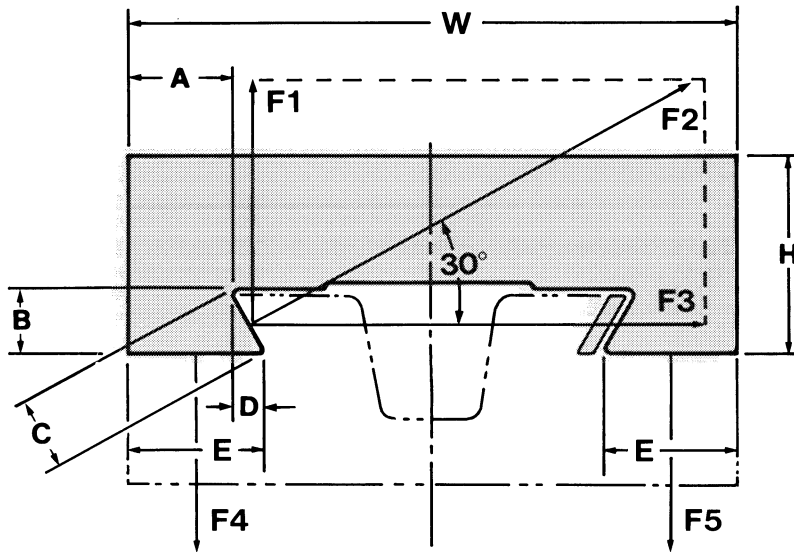

DOVETAIL SLIDE LOADING DIAGRAM

F₁ through F₅ represent forces applied to slide ways.

Model Number	Slide Width	DIMENSIONS IN INCHES			Effective Bearing Surface Areas Per Inch Of Carrier Length Engaged In Square Inches			
	W	H	A	B	C	D x 2	E x 2	
R2	2"	.75	.28	.36	.42	.42	.98	
R3	3"	.81	.40	.36	.42	.42	1.22	
R4	4"	1.06	.51	.49	.57	.58	1.60	
R6	6"	1.25	1.01	.49	.57	.58	2.60	
H4	4"	1.38	.54	.61	.70	.70	1.78	
H6	6"	2.00	1.03	.61	.70	.70	2.76	
H8	8"	2.00	1.40	.73	.84	.84	3.64	
RB3	3"	1.00	.32	.37	.43	.42	1.06	
RB4	4"	1.38	.54	.62	.72	.72	1.80	
RB6	6"	2.00	1.04	.62	.72	.72	2.80	
RB8	8"	2.00	1.41	.73	.84	.84	3.66	
RB10	10"	2.43	1.32	.82	.95	.96	3.60	
RB12	12"	2.43	1.65	.82	.95	.96	4.26	
RB16	16"	3.25	2.23	1.37	1.58	1.58	6.04	
RB20	20"	3.88	3.05	1.62	1.87	1.88	7.98	
RB24	24"	4.50	4.36	2.00	2.31	2.32	11.04	
IPM2	2"	.63	.31	.32	.37	.38	1.00	
IPM3	3"	.81	.51	.42	.48	.48	1.50	
IPM4	4"	1.19	.52	.50	.58	.58	1.62	
IPM6	6"	1.56	.77	.69	.80	.80	2.34	
IPM8	8"	2.00	1.16	.88	1.02	1.02	3.34	
IPM10	10"	2.50	1.42	1.06	1.22	1.22	4.06	
IPM14	14"	2.75	2.34	1.25	1.44	1.44	6.12	
IPM16	16"	3.50	2.63	1.50	1.73	1.74	7.00	



CASE NO. 4

Vertical application, slide moves drilling spindle in position

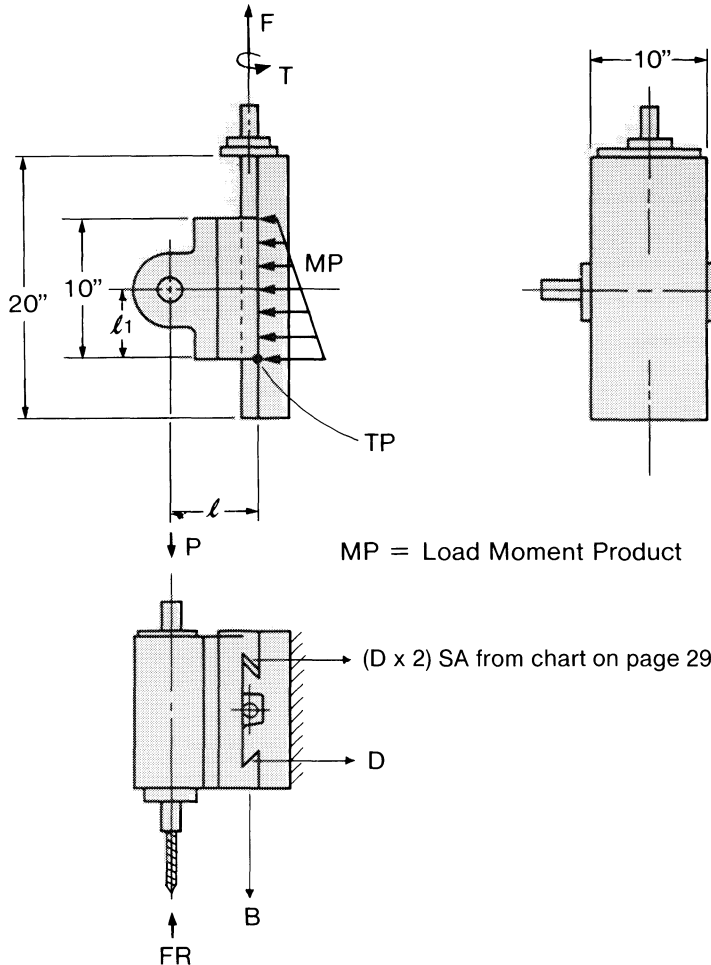

PARAMETERS

Model RB10-20-10-L

P = 180 lbs. spindle weight

l = 8 inches

FR = 400 lbs. thrust

WC = 39 lbs.

u = .23 (c.i. w/lube)

e = .30 (Acme Nut)

PS = .10 (1"-10 Acme)

LC = 10 inches

l1 = 5 inches

fl = 3.1416

$$SP = \frac{P \times l}{SA \times LC \times l_1} = \text{psi}$$

$$SP = \frac{180 \times 8}{.96 \times 10 \times 5} = 30 \text{ psi}$$

Recommended Max. 55 psi

Cantilever Load Condition force/torque required to raise carrier/spindle

$$F = \left(\frac{P \times l \times u}{l_1} \right) + WC + P = \left(\frac{180 \times 8 \times .23}{5} \right) + 39 + 180 = 285 \text{ lbs.}$$

$$T = \frac{F \times PS}{2fl \times e} = \frac{285 \times .10}{2fl \times .30} = 15.1 \text{ in. lbs.}$$

Due to variables in design, manufacture and parameters a service factor of 2 is recommended for final drive selection.

Note: In the above application the recommended maximum load FR can be determined using the chart on page 27.

$$FR = (SA \text{ of B} \times LC \times SP) = (.82 \times 10 \times 55) = 451 \text{ lbs.}$$



LUBRICATION SYSTEMS

ONE SHOT MANUAL LUBRICATOR

Our one-shot manual lubricator is required when controlled but infrequent oil feed is needed along with simplicity and economy. The one-shot system includes reservoir, junction header, metering units and the necessary piping and connections for mounting to the carrier or base.

MANUALLY OPERATED LUBRICATOR PUMP

The manually operated central pumping stations are used in applications that require a rugged high performance system which will provide a dependable high pressure source of lubrication. This pumping station includes reservoir, double-acting piston pump, reciprocated by a hand lever through a rack and gear segment, pump cycle indicator, level indicator, pressure relief, metering valves, support bracket and the necessary piping and connections for mounting.

DIRECT DRIVE LUBRICATOR PUMP

A direct drive system is basically used in production applications where neither pneumatic nor hydraulic power is available. Our system uses a fixed cam operated pump and crankshaft assembly which is driven by the mechanical motion of the slide. Included with the cam pump assembly is a reservoir, pump cycle indicator, level indicator, pressure relief, metering valves, support bracket and the necessary piping and connectors for mounting.

MACHINE CYLINDER CONTROLLED LUBRICATOR

This system utilizes the slide's pneumatic or hydraulic powered cylinder to actuate the double acting adjustable piston pump assembly so that a measured amount of oil will be delivered to each load bearing point. This system includes a reservoir, pump cycle indicator, level indicator, pressure relief, metering valves, support bracket and the necessary piping and connectors for mounting.

PNEUMATIC POWERED TIMER CONTROLLED LUBRICATOR

These timer controlled-pneumatic powered systems are fully automated to insure a predetermined amount of oil to be delivered to each bearing point from a minimum of once every fifteen minutes to a maximum of once every four hours. This system includes timer control in NEMA 12 enclosure, reservoir, pump cycle indicator, level indicator, pressure relief, metering valves, support bracket and the necessary piping and connectors for mounting.

LUBRICANTS

OILS

The following oils are recommended for all slides and screw drives. It is also recommended in cold areas in winter to use a lubricant of viscosity lower by one grade than the one specified. Self-lubricating Turcite "B" slideways must also be lubricated in the same manner as the cast iron or steel slideways.

- CALTEX UNIWAY OIL 68
- SHELL TONNA OIL T78
- GULF DAPHNE MULTIWAY 68
- MOBILE VACTRA OIL NO. 2
- ESSO FEBIS OIL K-68
- DIAMOND SLIDEWAY 68

TURBINE OIL SPRAY

For ballway type slide and ball screws.

- MOBILE DTE OIL LIGHT
- SHELL TURBO OIL T32
- ESSO TERESSO 32

GRAPHITE POWDER

Slideways with self-lubricating composite thermoplastic materials can be run dry or with graphite lubrication, provided that the mating surface is nickel plated.

Slideway materials are as follows:

(GULF) Ryton BG-1326, (PPS) Polyphenylene sulfide resin with carbon fibers, graphite and teflon.

(AMOCO) Torlon 4301 or 4275 poly (Amide-Imide) Resin with graphite powder, PTFE, (Polytetrafluoroethylene).

GREASES

Greases are to be used on ballway slides and ball screws "ONLY". The following greases are recommended by Milwaukee Slide and Spindle Company.

SHELL OIL CORP.

DARINA EP-0 — Petro base with Inorganic Microgel Thickner -30 degrees to +275 degrees F.

ALVANIA EP-2 — Petro base with Lithium Soap thickner -30 degrees to +275 degrees F.

MOBILE OIL CORP.

MOBILTEMP SHC 32 — Nonsoap grease with a synthatic-Hydrocarbon base fluid. -65 degrees to +350 degrees F.

AMOCO OIL CORP.

SUPERMIL GREASE NO. A72832 — Diester Type Oil with Lithium soap thickener -100 degrees to +250 degrees F.

NOTE: 5 - 10 are petro base with polyamidocarbonyl (polyurea) thickener.

- Rykon Prem. No 1 Rykon Prem. EP 2
- Rykon Prem. No 2 Rykon Prem. Moly (1)
- Rykon Prem. EP 1 Rykon Prem. Moly (2)

-30 degrees to +350 degrees F

SLIDE ACCURACY

Assembled parallelism and tracking of MILWAUKEE SLIDE AND SPINDLE slides.

MODELS R = .002 in. per foot cumulative (milled) or .0005 in. per foot cumulative (scraped)

MODELS H & RB = .001 in. per foot cumulative (milled) or .0005 in. per foot cumulative (scraped)

MODELS HW, HUB & HB = .0005 in. per foot cumulative

DRIVE SCREW ACCURACY

Vee thread lead screw = .001 in. per foot lead tolerance

Acme thread lead screw = .001 in. per foot lead tolerance

The lead error will accumulate per foot more than one half the lead tolerance per foot.

BALL THREAD LEAD SCREWS

Rolled threads = .003-.009 in. per foot lead tolerance

Ground threads = .0005-.001 in. per foot lead tolerance

DRIVE NUT BACKLASH

In the Vee thread and Acme thread-nut, the backlash can be assumed to be .002 inch maximum. Our anti-backlash nut will reduce this tolerance to approximately .0005 inch.

BALL NUT ASSEMBLY

The backlash on standard ball nuts is approximately .005 inch. Preloaded ball nuts backlash is zero.

Closer tolerances are available upon request.

LINEAR BEARING PROFILES -- WHO and HOW

For many years Milwaukee has been testing linear bearings, and shown below are the finest precision bearings available. In applied research and machine slide applications, we can recommend the best bearing for your particular slide.

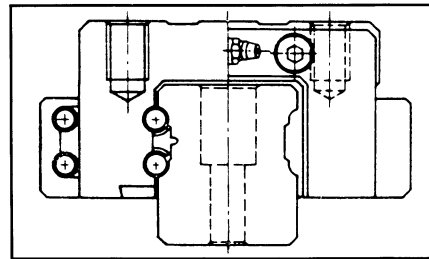

TSUBAKI/(TSUBAKIMOTO PRECISION PRODUCTS CO., LTD)

- a. Back-to-back-design (rigid)
- b. Ball recirculation (excellent), all steel tube type
- c. Circular arc grooves, long line contact, large ball race ways

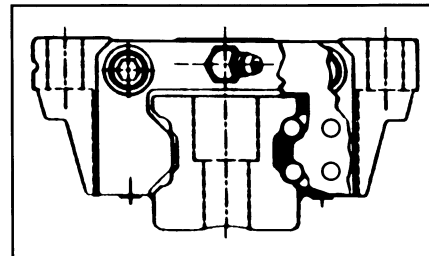

TYCHOWAY/(HEPHAIST PRECISION PRODUCTS CO., LTD)

- a. Back-to-back-design (rigid)
- b. Ball recirculation (limited), plastic end cap type
- c. Circular arc groove, long line contact, small ball race ways

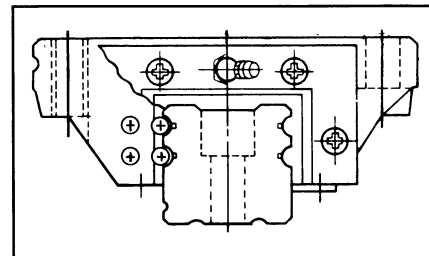

NSK/(NIPPON SEIKO K.K.)

- a. Back-to-back-design (rigid)
- b. Ball recirculation (limited), plastic end cap type
- c. Circular arc groove, short line contact, small ball race ways

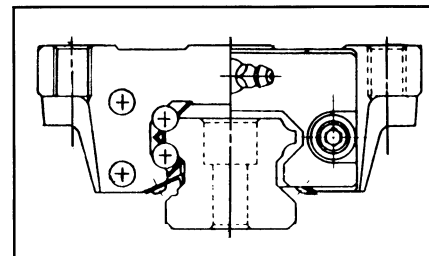

THK/(TOHO SEIKO CO., LTD)

- a. Face-to-face-design (flexible)
- b. Ball recirculation (limited), plastic end cap
- c. Circular arc groove, long line contact, large ball race ways

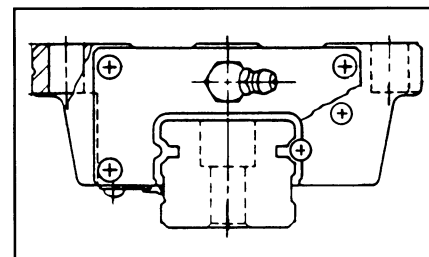

IKO/(NIPPON THOMPSON CO., LTD)

- a. Two circuit single row design
- b. Ball recirculation (limited), steel band plastic end cap
- c. Gothic arc groove, 4-point contact, large ball race ways



Milwaukee Quality Machine Bases — standard and custom designed bases for machining, assembly, electronics, robotics, testing, gaging, and inspection applications.

HEAVY TABLE BASE STYLE 10A
OTHER COMBINATIONS POSSIBLE!

DIMENSIONS IN INCHES				Approx. Weight (lbs.)
Model	W x L	H ¹	T ²	
T24-10A24	24 x 24	32	¾	264
			1	305
			1½	386
T30-10A30	30 x 30	32	¾	349
			1	413
			1½	540
T36-10A36	36 x 36	32	¾	450
			1	542
			1½	725
T42-10A42	42 x 42	32	¾	567
			1	692
			1½	942
T48-10A48	48 x 48	32	1	861
			1½	930
			1¾	976
T60-10A60	60 x 60	32	1	1261
			1½	1770
			1¾	2025
T72-10A72	72 x 72	32	1	1744
			1½	2474
			1¾	2841

¹32" is standard height. Other heights possible. Specify desired height.

²3/4" is standard top plate thickness, other thicknesses available.

Coolant trough, bolt on top, shelves and other options available. Surface grinding available on tables up to 60" wide.

SELECT ANGLE SIZE (IN.)

Cross Brace	2½ x 1½ x ¼	3 x 2 x ¼	3½ x 2½ x 5/16
Leg	3½ x 3½ x ¼	4 x 4 x ¼	5 x 5 x 5/16

Bases less than 84" long will have:
 4 legs 4" x 4" x 1/4" angles
 8 horizontal braces 3" x 2" x 1/4" angles

Bases 84" and longer:
 4 - 5" x 5" x 5/16" legs
 2 - 4" - 5.4# channels
 10 - 3-1/2" x 2-1/2" x 5"

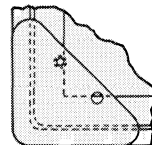
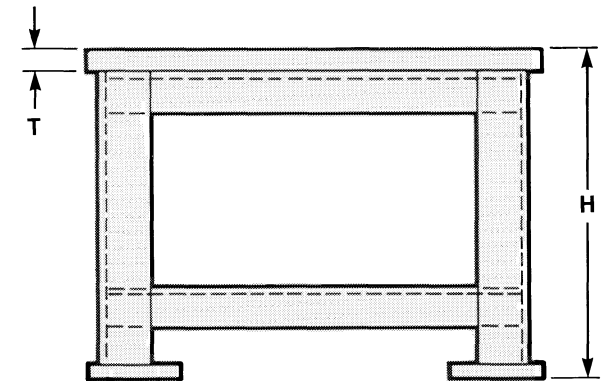
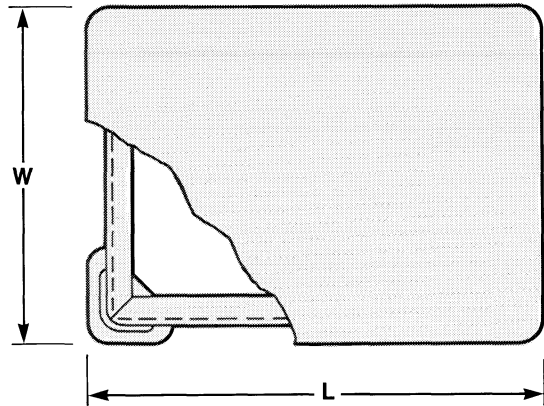
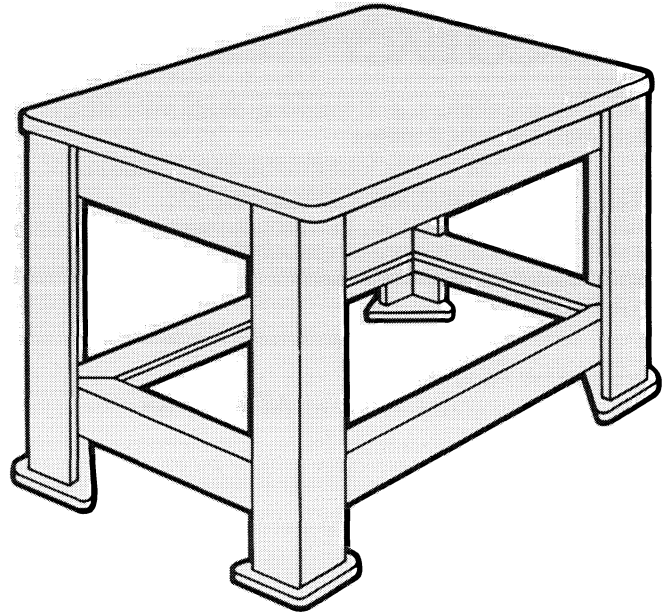

STANDARD PADS

One 1/2-13 tapped hole and one 17/32 drilled hole in pads style B & C.

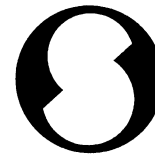

STYLE 10A and STYLE 10B

- Rugged welded steel
Other materials are optional
- Blanchard Ground Top Plate
Surface grinding optional
- Gray enamel paint
Paint of your choice optional

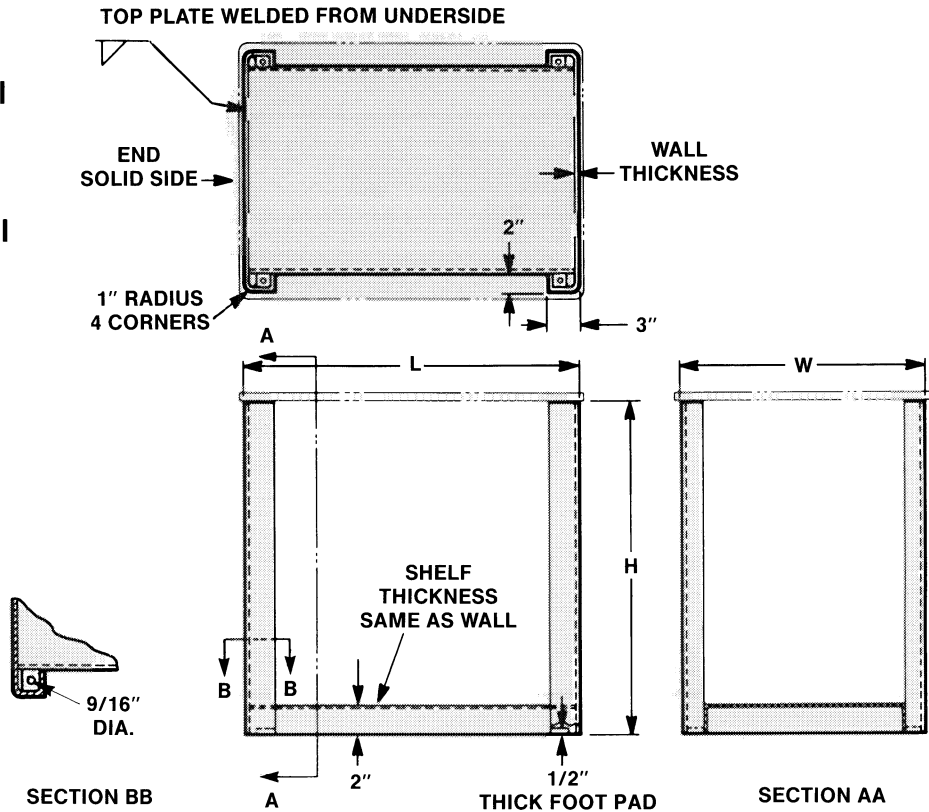

TABLE BASE STYLE 10B OTHER COMBINATIONS POSSIBLE!

Model	DIMENSIONS IN INCHES			Approx. Weight (lbs.)
	W x L	H ¹	T ²	
T18-10B18	18 x 18	32	3/4	200
T18-10B24	18 x 24	32	3/4	231
T18-10B30	18 x 30	32	3/4	266
T24-10B24	24 x 24	32	3/4	298
T24-10B30	24 x 30	32	3/4	340
T24-10B36	24 x 36	32	3/4	381
T24-10B48	24 x 48	32	3/4	463
T30-10B30	30 x 30	32	3/4	412
T30-10B36	30 x 36	32	3/4	449
T30-10B48	30 x 48	32	3/4	565
T36-10B36	36 x 36	32	3/4	597
T36-10B48	36 x 48	32	3/4	668

¹32" is standard height. Other heights possible.
Specify desired height.

²3/4" is standard top plate thickness. Other thicknesses available.

Coolant trough, bolt on top, surface grinding, and other options available.

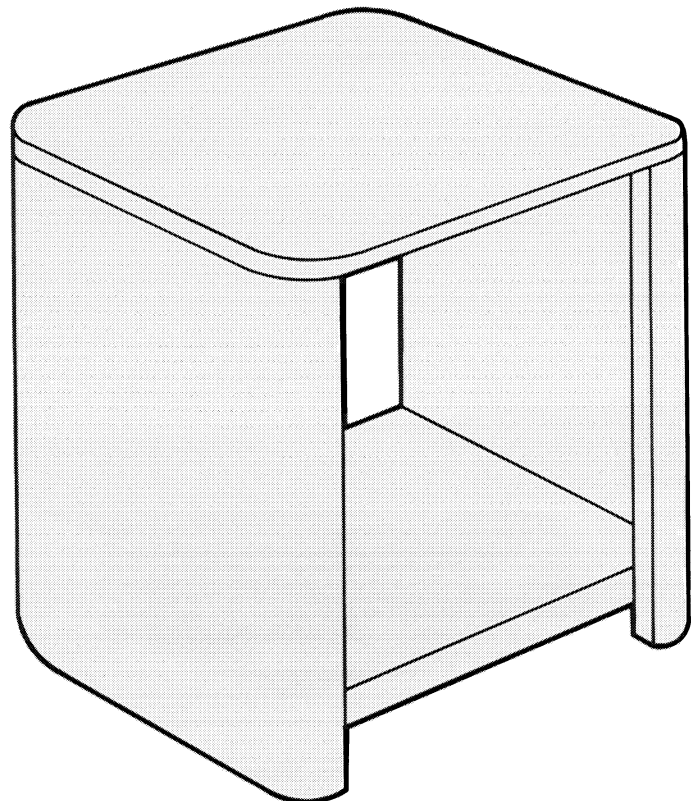

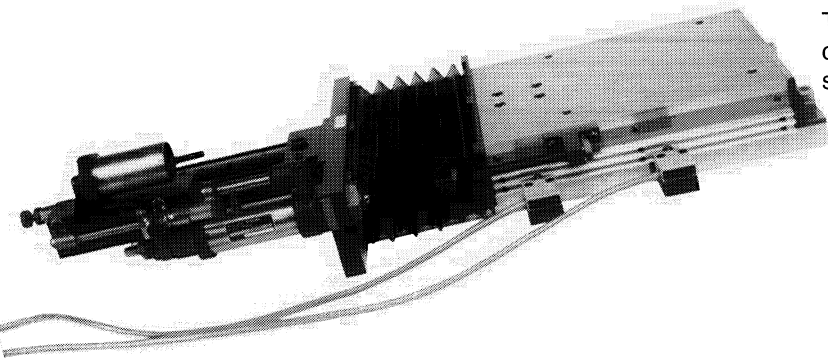

This slide is shown with limit switch system and hydrocheck. The hydrocheck controls the speed of travel. The slide is excellent for high load and smooth action.

Low Profile Ball-Way Slide with Hydrocheck

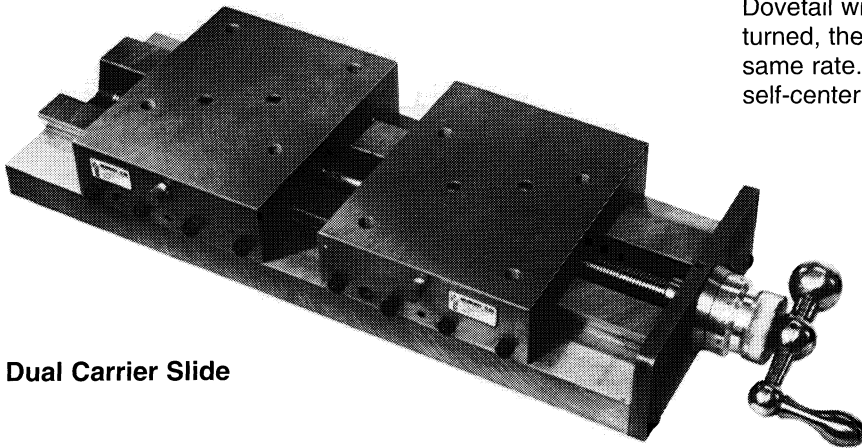

This standard module is made up from a recessed base Dovetail with two slide carriers. When the crank handle is turned, the carriers move together or move apart at the same rate. This feature is very desirable in cases where self-centering clamping or positioning is required.

Dual Carrier Slide

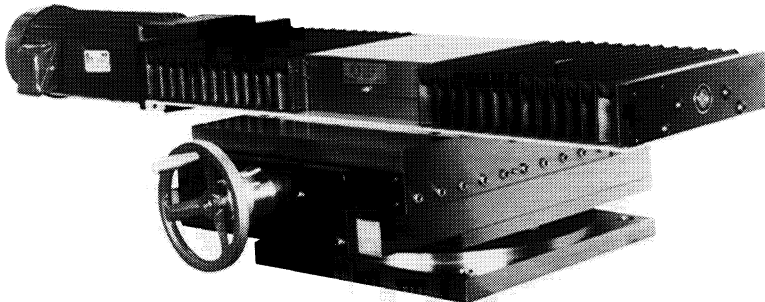

This 12" heavy duty recessed base dovetail slide is motor operated and mounted on a 20" slide, handwheel operated. Third axis is provided by a 20" diameter rotary positioner.

Combination Slide and Rotary Table

This multi-compound slide unit is used in welding operation for automotive batteries. Special angle plates, right angle drives, and right-hand/left-hand lead screws for self centering operation.

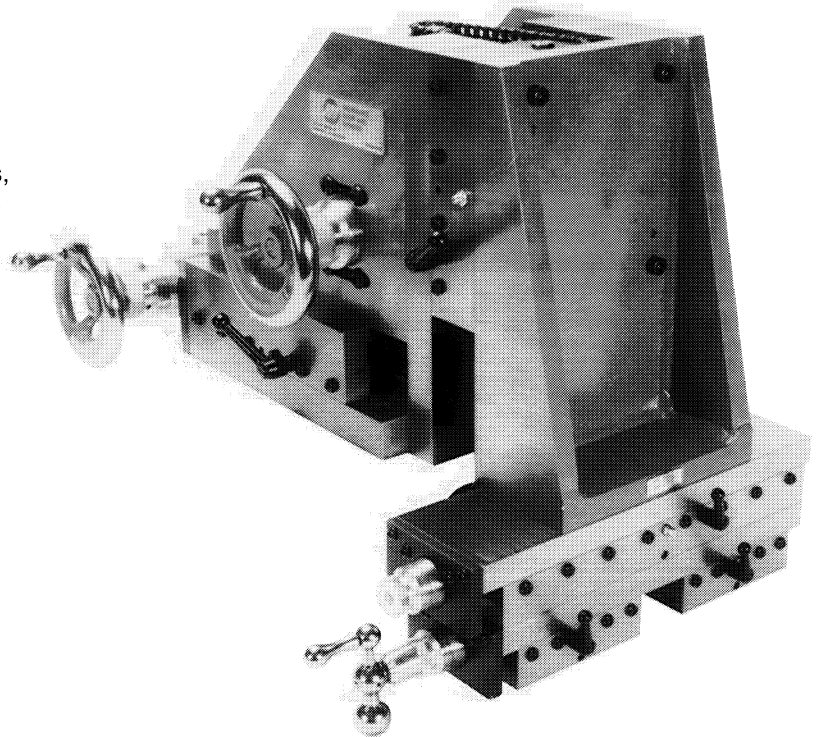

Special Dovetail Slide Assembly

This assembly uses two low profile ball-way slides and a precision milling spindle. The ball-way slides are driven with air cylinders and hydrochecks for smooth consistent motion. Notice the shock absorbers on the horizontal axis. Also, notice the spindle motor and mounting device is included.

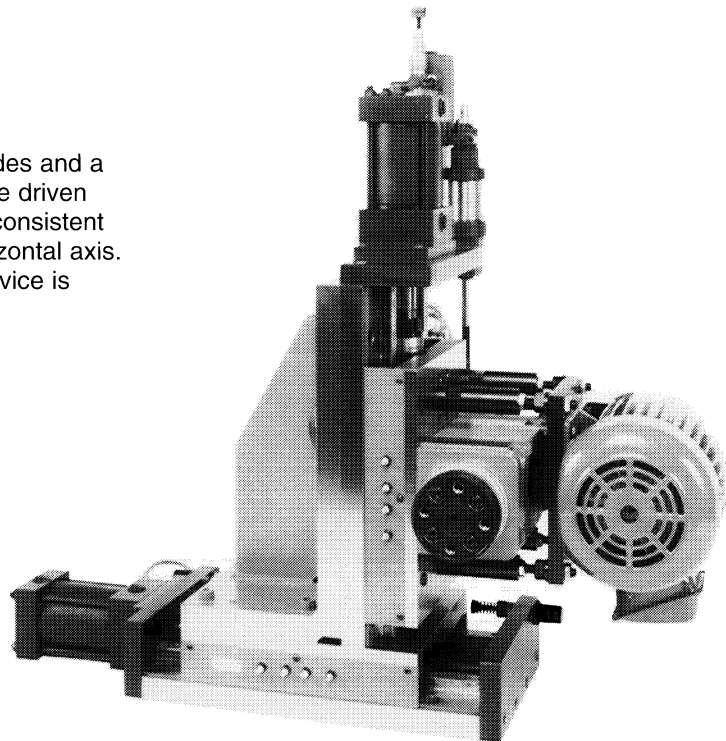

Two Axis Milling Station

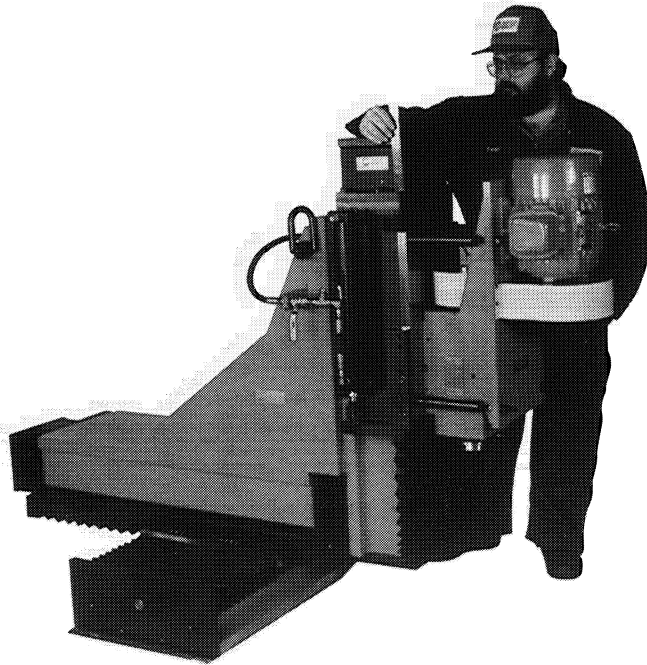

3 axis vertical spindle unit shown with motor adapter brackets and drilling/milling spindle unit.

Three Axis Vertical Machining Station

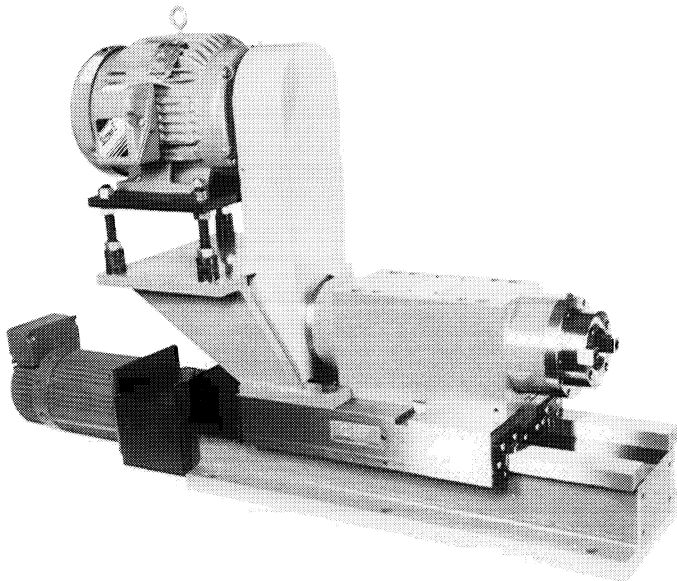

Single axis horizontal drilling/milling unit mounted on hardened motor driven way slide.

Single Axis Hardened Way Slide

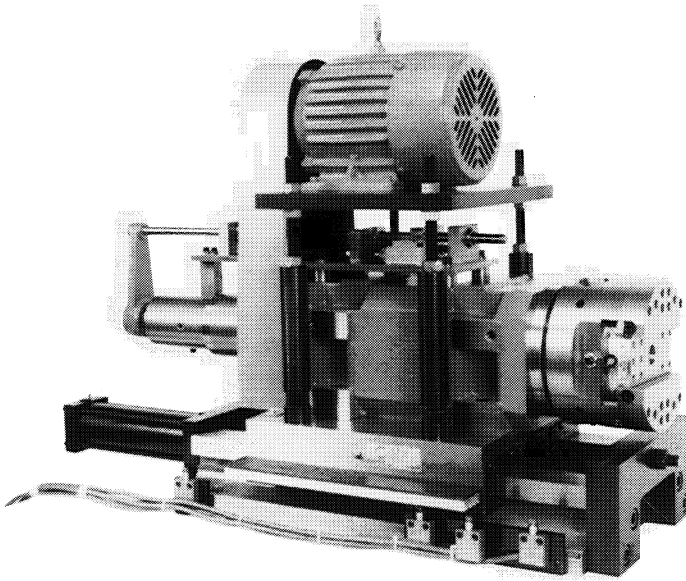

This single axis hardened way slide and spindle assembly is used to manufacture pump bodies for the automotive industry. It uses a special facing head on the spindle for cross-feeding a single point tool. Notice the limit switch system and positive stops.

Precision Facing Spindle on Hardened Way Slide

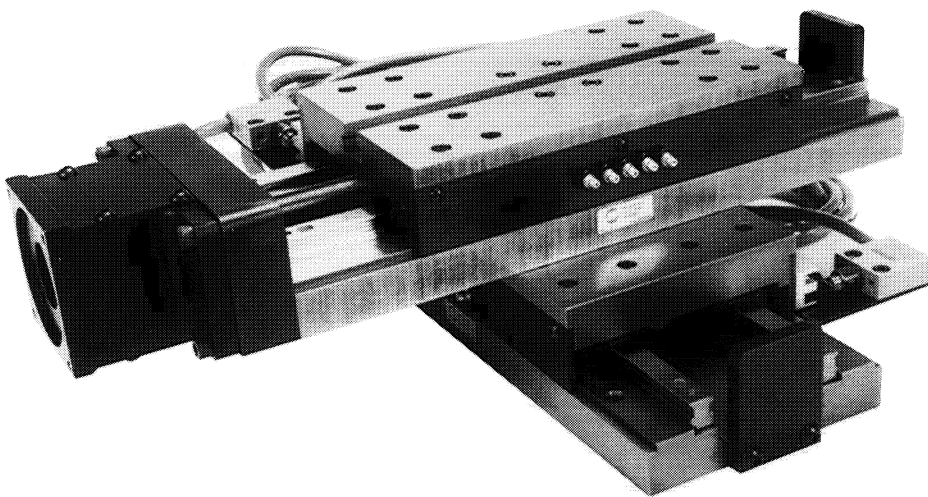

This two axis slide assembly is shown with custom tee slots, motor mount brackets, and limit switch system. Special 40-pitch screw for very fine movement also supplied. Notice lubrication system for the linear bearings and lead screw nut.

Two Axis Ball-Way Slide Assembly

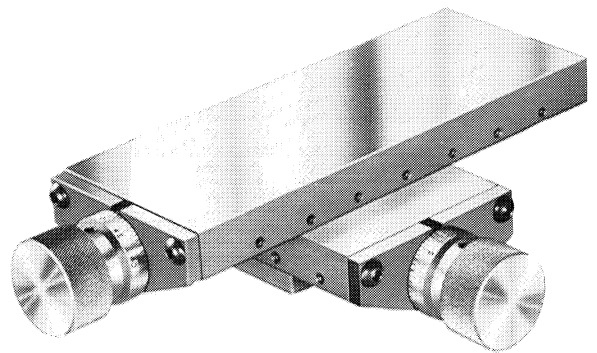
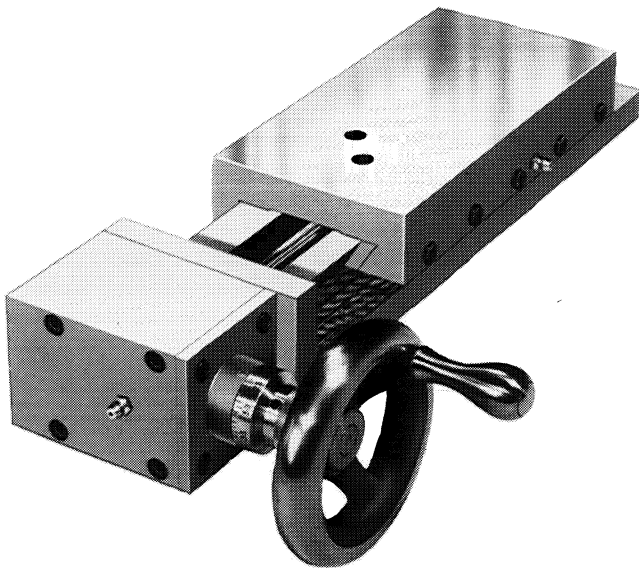
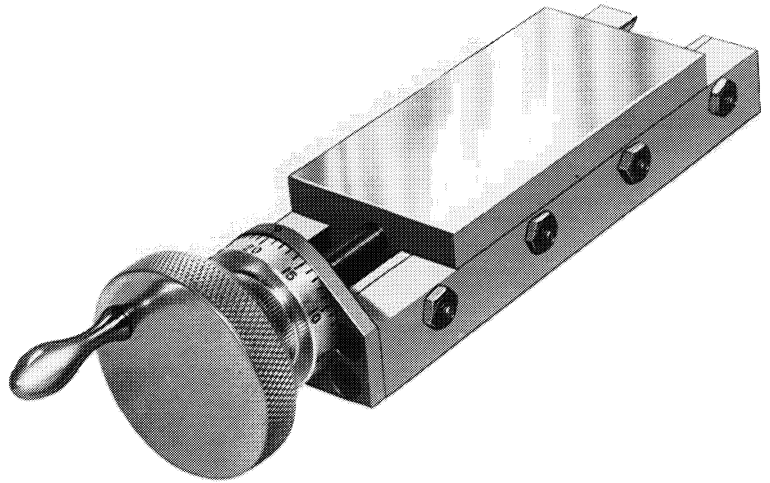
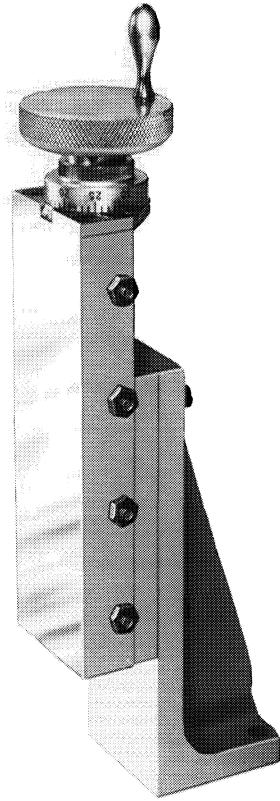



ENGLISH AND (SI) UNITS OF MEASURE

Length

1 centimeter	= 0.3937 inch	= 0.0328 foot
1 meter	= 39.37 inches	= 1.0936 yards
1 kilometer	= 0.62137 mile	= 3281 feet
1 inch	= 2.54 centimeters	= 25.4 millimeters
1 foot	= 0.3048 meters	= 12 inches
1 mil	= 0.001 inch	
1 micron	= 0.00004 inch	

Square Measure

1 sq. cm	= 0.1550 sq. in.	= 100 sq. mm
1 sq. m	= 1.196 sq. yd.	= 10.764 sq. ft.
1 sq. km	= 0.386 sq. mile	
1 sq. inch	= 6.452 sq. centimeters	
1 sq. foot	= 929.03 sq. cm	= 0.092903 sq. meter
1 sq. yard	= 0.8361 sq. meter	
1 sq. mile	= 2.59 sq. kilometers	= 640 acres
1 circular mil	= 0.7854 sq. mil	
1 sq. inch	= 1,000,000 sq. mils	

Cubic Measure

1 cu. centimeter	= 0.061 cu. inch
1 cu. in.	= 16.39 cu. cm
1 cu. meter	= 1.308 cu. yards = 35.316 cu. feet
1 gallon (U.S.)	= 231 cubic inches = 3.79 liter
1 cu. ft.	= 7.48 gal.
1 liter	= 1,000 cu. centimeters
1 CFM	= 28.03 liters/min.
1 liter/min.	= 0.0356 CFM

Time

1 day	= 86,400 seconds
1 year	= 8,760 hours (approx.)

Velocity

1 ft/sec	= 0.3048 meters/sec
1 meter/sec	= 3.281 ft/sec
1 ft/minute	= 0.00508 meter/sec
1 meter/sec	= 196.9 ft/min
1 mile/hr	= 0.4470 meter/sec
1 meter/sec	= 2.237 mi/hr
1 kilometer/hr	= 0.2778 meter/sec
1 meter/sec	= 360 km/hr

Acceleration

1 ft/sec/sec	= 0.3048 meter/sec/sec
1 mile/hr/sec	= 0.4470 meter/sec/sec
1 kilometer/hr/sec	= 0.2778 meter/sec/sec
Standard gravitation	= 9.806 meters/sec/sec
Standard gravitation	= 980.6 cm/sec/sec
Standard gravitation	= 32.2 ft/sec/sec

Mass

1 slug	= 32.17 pounds = 14.59 kilograms
1 pound mass	= 453.6 grams = 0.4537 kilograms = 16 ounces
1 kilogram	= 2.2046 pounds

Force

1 pound force	= 1 slug x 1 foot/sec/sec
1 dyne	= 1 gram x 1 centimeter/sec/sec
1 newton	= 1 kilogram x 1 meter/sec/sec
1 pound force	= 4.448 newtons
1 newton	= 100,000 dynes = 0.2248 pound force
1 gram force	= 980.6 dynes

Pressure

1 atmosphere	= 14.69 pounds/sq. inch = 29.92 in. of Hg. (MERCURY) = 76 cm of Hg. = 33.9 ft. of water
1 in. Hg.	= 0.491 pounds/sq. inch
Water pressure pounds/sq. inch = head in ft.	x 0.434
1 psi = 0.0703 Kg/sq. cm	
14.22 psi = 1 Kg/sq. cm	

Torque

Torque is the product of force and perpendicular distance	
1 lb.-ft. = 1.356 newton-meter = 1.356 joule/radian	
1 lb.-ft. = 1.356 x 10 ⁷ dynes-centimeter	
1 lb.-ft. = 1.383 x 10 ⁴ grams-centimeter	
1 lb.-ft. = 192 ounce-inches = 12 lb.-inches	

Work and Energy - Mechanical

1 erg	= 1 dyne x 1 centimeter
1 joule	= 1 newton x 1 meter = 10 ⁹ dynes x 10 ² cm-10 ⁷ ergs
1 ft lb	= 1 pound force x 1 foot = 1.356 joules

Work and Energy - Heat Equivalent

1 Btu raises 1 pound of water 1°F	
1 gram calorie raises 1 gram of water 1°C	
1 Btu = 252 gram calories = 778.3 ft-lb = 1054.8 joules	
1 gram calorie = 0.003964 Btu = 4.184 joules	
1 horsepower hour = 2545 Btu	

Work and Energy - Electrical Equivalent

1 joule	= 1 watt x 1 second = 1 amp (dc) x 1 volt (dc) x 1 sec
W (joules)	= 1/2 L (henries) x I (amperes) ²
W (joules)	= 1/2 C (farads) x E (volts) ²
1 kilowatt hour	= 3,600,000 joules

Power

1 watt	= 1 joule/sec
1 horsepower	= 550 ft lb/sec = 746 watts = 0.746 Kw
1 watt	= 3.413 Btu/hr = 0.239 gram calories/sec
P watts	= R (ohms) x I (amperes) ²

$$P \text{ watts} = \frac{E \text{ (volts)}^2}{R \text{ (ohms)}}$$

Angles

1 circle	= 2π radians = 360 degrees
1 radian	= 57.3 degrees
1 degree	= 0.01745 radians

Geometric Figures

Circle, area of = D ² x 0.7854 = πr ²	
r = radius	
Circle, circumference of = πD or 2πr	
Sphere, area of = πD ² = 4πr ²	
D = diameter	
Sphere, volume of = D ³ x 0.5236 = 4/3πr ³	
Triangle, area of = 1/2 altitude x base	
Cone, volume of = area of base x 1/3 altitude	
Trapezoid, area of = 1/2 (sum of parallel sides) x altitude	
Pyramid, volume of = area of base x 1/3 altitude	

Miscellaneous Constant

π = 3.14159	
e = 2.71828	
Log _e X = 2.30259 log ₁₀ X	
Electronic charge = 4.8 x 10 ⁻¹⁰ e.s.u. = 1.60 x 10 ⁻²⁰ e.m.u.	
Mass units = 1 x 10 ⁻⁹ x Mev = 6.71 x 10 ² ergs	
Speed of light = 186,280 miles per second	
Speed of sound (in air at sea level) = 1,090 ft./sec.	
Speed of electricity = 186,000 miles per second	
Speed of the earth through space = 43,000 miles per hour	
Distance from the earth to the moon = 237,000 miles	
Distance from the earth to Venus = 25,000,000 miles	
Distance from the earth to Mars = 35,000,000 miles	
Distance from the earth to the Sun = 93,000,000 miles	
Length of a light year = 5,880,000,000 miles	
Length of a mile = 5,280 feet	
Length of furlong = 660 feet	
Length of a rod = 16.5 feet	
Length of a fathom = 6 feet	
Length of a hand = 4 inches	

Exponents - The figures 10⁻¹, 10⁻², 10⁻³ etc. denote 0.1, 0.01, 0.001, etc. respectively
The figures 10¹, 10², 10³, etc. denote 10, 100, 1000, etc. respectively

Torque and Horsepower

$$T = F \times r$$

$$T = \frac{63025 \times \text{HP}}{\text{RPM}} \quad \text{HP} = \frac{T \times \text{RPM}}{63025} \quad \text{RPM} = \frac{63025 \times \text{HP}}{T}$$

T = Torque in inch/pounds, rotary force to or from a drive shaft

F = Force in pounds, a force applied to a drive shaft from a given distance to produce rotary motion

r = Radius in inches, a distance from a given point of force to the center line of the drive shaft axis

HP = Horsepower, power required to rotate drive shaft at a given speed

RPM = Revolutions per minute, number of turns a drive shaft makes in one minute.

Equivalents of Common Fractions of an Inch

64ths	32nds	16ths	8ths	Decimal	Mm
1/64				0.01562	0.397
	1/32			0.03125	0.794
3/64				0.04688	1.191
		1/16		0.06250	1.588
5/64				0.07812	1.984
	3/32			0.09375	2.381
7/64				0.10938	2.778
			1/8	0.12500	3.175
9/64				0.14062	3.572
	5/32			0.15625	3.969
11/64				0.17188	4.366
		3/16		0.18750	4.763
13/64				0.20312	5.159
	7/32			0.21875	5.556
15/64				0.23438	5.953
			1/4	0.25000	6.350
17/64				0.26562	6.747
	9/32			0.28125	7.144
19/64				0.29688	7.541
		5/16		0.31250	7.938
21/64				0.32812	8.334
	11/32			0.34375	8.731
23/64				0.35938	9.128
			3/8	0.37500	9.525
25/64				0.39062	9.922
	13/32			0.40625	10.319
27/64				0.42188	10.716
		7/16		0.43750	11.113
29/64				0.45312	11.509
	15/32			0.46875	11.906
31/64				0.48438	12.303
			1/2	0.50000	12.700
33/64				0.51562	13.097
	17/32			0.53125	13.494
35/64				0.54688	13.891
		9/16		0.56250	14.288
37/64				0.57812	14.684
	19/32			0.59375	15.081
39/64				0.60938	15.478
			5/8	0.62500	15.875
41/64				0.64062	16.272
	21/32			0.65625	16.669
43/64				0.67188	17.066
		11/16		0.68750	17.463
45/64				0.70312	17.859
	23/32			0.71875	18.256
47/64				0.73438	18.653
			3/4	0.75000	19.050
49/64				0.76562	19.447
	25/32			0.78125	19.844
51/64				0.79688	20.241
		13/16		0.81250	20.638
53/64				0.82812	21.034
	27/32			0.84375	21.431
55/64				0.85938	21.828
			7/8	0.87500	22.225
57/64				0.89062	22.622
	29/32			0.90625	23.019
59/64				0.92188	23.416
		15/16		0.93750	23.813
61/64				0.95312	24.209
	31/32			0.96875	24.606
63/64				0.98438	25.003
			1	1.00000	25.400



CORPORATE HISTORY

In 1927 Mr. Herman Noll purchased the then Freeze and Miller Company, forming his new corporation Famco Machine Company. Since then Famco has continued as an American machine tool manufacturer of arbor, air and foot presses as well as power squaring shears.

In 1975, the company was sold to Belco Industries, Inc. and continued in the manufacture of former products under the Famco Machine Division banner.

In 1987, Famco acquired the Gorton Machine Tool products along with the Lars Corporation products and moved same to its newly expanded Kenosha facility. These products include the Gorton pantograph (engraving) line as well as the Lars tool and cutter grinders.

In 1994, William Blasi purchased 100% of the assets of Famco Gorton/Lars.

In 1996, Famco Machine Division, Belco Industries Incorporated acquired the assets of Milwaukee Slide and Spindle Company.

Famco is located on approximately 12 acres in Kenosha, Wisconsin. The current building is 55,000 square feet and is home for corporate offices, engineering, sales, manufacturing and purchasing.

The average length of service of Famco's manufacturing personnel is approximately 16 years.

FAMCO
MACHINE DIVISION



GORTON



MILWAUKEE
SLIDE AND
SPINDLE

**– MANUFACTURERS OF FAMCO/GORTON-LARS PRODUCTS/
MILWAUKEE SLIDE AND SPINDLE PRODUCTS –**

Four Easy Ways to Reach Us!



Phone:
1-800-882-6331 (Toll Free)
262-654-3516 (Local)



Mail to:
FAMCO MACHINE DIVISION
BELCO INDUSTRIES, INC.
1001 – 31st Street
Kenosha, WI 53140-1926

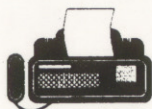

Fax:
262-654-0803 (Local)



Internet:
<http://www.milwaukeeeslide.com>
E-Mail: SALES@FAMCOmachine.com